



Doosan Infracore Korea Office (HQ)
 27/F, Doosan Tower 18-12, Euljiro-6Ga, Jung-Gu
 Seoul 100-730 Korea
 Tel : 82 2 3398 8114

www.doosaninfracore.com/ce/



DX35z

Engine Power : SAE J1995, gross 20.3 kW(27.2HP)@2,200rpm

SAE J1349, net 19.5 kW(26.1HP)@2,200rpm

Operational Weight : Canopy 3,560 kg (7,848 lb)- STD.

Cabin 3,660 kg (8,069 lb)- STD.

Bucket capacity(SAE) : 0.11m³ (0.144 cu.yd)



Doosan DX35z Hydraulic Excavator :

A New Model with Novel Features



DX
35z



The new DX35z hydraulic excavator has all the advantages of the previous model, and now offers additional added value to the operator.

The new DX35z was developed with the concept of “providing optimum value to the end user.” In concrete terms, this translates, into :

Increased production and improved fuel economy is attributed to the electronic optimization of the hydraulic system and the new generation engine (Tier III / Stage III).

Improved ergonomics, increases comfort and excellent all round visibility ensuring a safe and pleasant working environment.

Improved reliability is achieved through the use of high performance materials combined with new methods of structural stress analysis, and leads to increased component life expectancy, thus reducing running costs.

Reduced maintenance increases the availability and reduces operating costs of the excavator.

PERFORMANCE

The highest performance is guaranteed in any working condition.

The advanced hydraulic system combined with a powerful engine provides for powerful excavation and work efficiency as well as the biggest break out and tractive forces.

As a result the DX35z provides outstanding performance, work efficiency and the ability to adapt to any work environment.



3TNV88 Engine
The DX35z has a powerful and eco-friendly Heart, that always provides high operating efficiency and pleasant working conditions.



E/G Control Lever
The engine control lever is placed in a very convenient location easily accessible by the operator to easily control the engine speed.



Powerful Digging Force (Bucket)
Powerful, efficient digging with increased digging force
Bucket Digging force : (3.01 ton)



Dozer Blade
Welded, unitized blade provides durability even under harsh working conditions
1,700 mm x 350 mm (5'7" x 1'2")

Boom swing
The convenient boom swing function provides the ability to work in very narrow areas. The newly designed swing bracket and the increased boom cylinder size ensures powerful and stable boom swing performance.

COMFORT

The cabin has been ergonomically redesigned with comfort in mind.

Starting a fresh, the newly designed DX35z provides the operator with maximum comfort and various convenient features. The DX35z is the result of an innovative technical design!

The cabin space is more comfortable than any other excavator in its class.



Comfortable Operating Cabin

A roomy, minimal shock and low noise operator's cab with safety glass windows on all four sides provides all-round visibility in the front, rear, sides up and down. The right side window opens for ventilation.



Cabin type ↑



Canopy type →



Control Stand

The left and right control stands are ergonomically placed for convenient operation. The control stand surfaces have ample room to install several option switches. The uni-body plastic design provides the operator with a spacious and comfortable cabin environment.



Switch

The ergonomically placed switches maximize convenience for the operator.



Cup Holder

The conveniently located cup holders add to the comfort of the cabin.



Monitor

The centralized display panel provides comprehensive information about the status of the machine in an easy to read format. The high quality display panel is waterproof and all information can be seen at a glance.



Joystick

The hydraulic joystick levers have very comfortable grips that allow the operator to perform precise operations very easily.



Arm Rest

The arm rests provide the operator comfort during long working days. The arm rests have been relocated to the control stand and provide more comfort to the operator than those with arm rests on the seat.



Defroster

The high capacity ventilation system is installed at the right and the rear windows and provides excellent performance in both cold and hot conditions. Eliminating both frost and moisture very efficiently, provides a safer working condition for the operator in any weather condition. (Cabin Type Only)



Comfortable Sliding Seat



Control Stand Tilt Function



Floor Plate (Rubber mat)

The breaker pedals (left) and boom swing pedals (right) are installed in a very spacious and convenient location. In addition, the rubber floor mats contribute to a very comfortable environment. The door opening has been increased by removing the lower lip which provides easy cleaning of the interior.



Rear Camera

MAINTENANCE

The status and condition of all components can be seen at a glance. The convenient and easy serviceability is really distinguished.

The most advanced technology developed by Doosan Infracore Co., Ltd. was integrated into the DX35z excavator providing powerful performance and simple, easy maintenance. This provides the operator with convenient maintenance check points and maximizes the work efficiency of the DX35z.



DX
35z



Strengthened Boom

The shape of the boom has been optimally designed using finite elements and 3-dimensional computer simulation, allowing the loads to be better distributed throughout the structure. This combined with increased material thickness means improved durability and reliability by limiting element fatigue.

Arm Assembly

In the arm assembly greater strength is gained by using cast elements and reinforcement around the bosses to give increase the life of the component.



X-chassis

The X-chassis frame section has been designed using finite element and 3-dimensional computer simulation, to ensure greater durability and optimum structural integrity. The swing gear is solid and stable.



Main Frame

The main frame and chassis frame add strength and minimize distortion due to shocks.



Engine Room

The engine compartment is designed for easier service and the sturdy sound proofing inside the engine cover reduces the noise to provide a more comfortable environment for the operator and the residents in urban areas.



Easy maintenance

Access to the various radiators is very easy, making cleaning more convenient. The battery and washer fluid level can be checked easily.



Air cleaner

The large capacity forced air cleaner removes over 99% of airborne particles, reducing the risk of engine contamination, making the cleaning and cartridge change intervals greater.



Air Breather

The hydraulic system was designed to prevent the pump from cavitation.



Bucket

Hardened bucket claws provide durability and can be easily unbolted for removal, straightening or replacing.



Oil Gauge

Hydraulic oil level can be easily checked through the gauge on the side of the hydraulic tank.



Grease Piping

Integrated grease piping is designed for ease maintenance of the swing bearing and swing cylinder.



Rubber tracks

The rubber shoes not only offers greater non-slip and grip capabilities but is less harmful to sidewalks and road surfaces in urban environments than conventional steel shoes. These rubber shoes can be easily installed or removed with the idler, sprocket and other main parts.

TECHNICAL SPECIFICATIONS



* ENGINE

• Model	YANMAR, 3TNV88
• Number of cylinders	3
• Nominal flywheel power	20.3 kW(27.2 HP) @2,200 rpm (SAE J1995, gross) 19.5 kW(26.1 HP) @ 2,200 rpm (SAE J1349, net)
• Max torque	11.2 kgf.m(110 Nm) at 1,200 rpm
• Piston displacement	1,642 cc (100 cu.in)
• Bore & stroke	Φ88 mm x 90 mm (3" X 4")
• Starter	12 V x 1.7 kW
• Batteries	1 x 12 V / 80 Ah
• Alternator	12 V / 40 Ah

* HYDRAULIC CYLINDERS

High-strength piston rods and tubes are used. A cylinder cushion mechanism is provided for the boom and arm cylinders to assure shock-free operation and extend the life of the cylinders.

Cylinders	Quantity	Bore x Rod diameter x stroke
Boom	1	80 X 45 X 630mm(3.1" X 1.8" X 2'1")
Arm	1	80 X 45 X 605mm(3.1" X 1.8" X 2')
Bucket	1	70 X 40 X 515mm(2.8" X 1.6" X 1'8")

* SUPER-STRUCTURE REVOLVING FRAME

A deep, full-reinforced box section. Heavy gauge steel plates used for ruggedness.

* OPERATOR'S CAB

A roomy, shock independent and low noise operator's cab, four-side safety glass windows gives excellent all-round visibility. Front window slides up and stores in the roof and side window can be opened for ventilation. Fully adjustable suspension seat. Air conditioner. ISO standard cab.

Noise Levels (dynamic value)

LwA External noise	
Guaranteed Sound Power Level	94dB (A) (2000/14/EC)
LpA Operator noise	81dB (A) (ISO 6396)

* HYDRAULIC SYSTEM

2 Variable displacement axial piston tandem type pumps.
2 Gear pumps and control valve (9-spool) of section block construction. This original design enables both independent and combined operations of all function, joystick control type levers.

• Main pumps	2 variable displacement axial piston pumps max flow: 2 x 38.5 ℓ /min + 23.5 ℓ /min (2 X 10.2 US gpm + 6.2 US gpm, 2 X 8.5 lmp gpm + 5.2 ℓ /min)
• Pilot pump	Gear pump - max flow: 11.2 ℓ /min (3 US gpm, 2.5 lmp gpm)
• Maximum system pressure	Boom/Arm/Bucket: 230 kgf/cm ² (225 bar) Travel: 230 kgf/cm ² (225 bar) Swing: 200 kgf/cm ² (196 bar)

* CONTROL.2 IMPLEMENT LEVERS

Travel lever pedal pilot pressure control type. Right lever is boom and bucket control, left lever for swing and arm control.

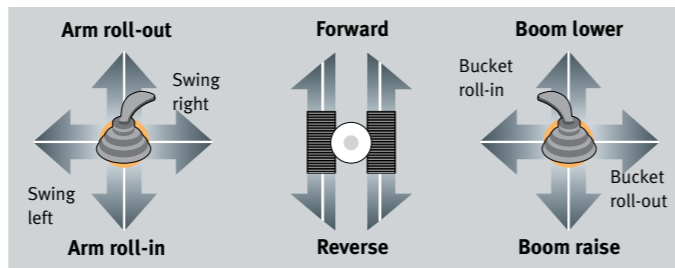

* TRAVEL LEVERS

Pedal pilot pressure control type. Independent drive at each track allows counter-rotation of the tracks. Levers are detachable.

* SWING MECHANISM

High-torque, axial piston motor with planetary reduction gear bathed in oil. Swing bearing is single-row, shear type ball bearing with induction-hardened internal gear. Internal gear and pinion gear immersed in lubricant. A two position swing lock secures the upper structure for transportation.

• Swing speed:	9.53 rpm
• Rear swing radius:	850mm(2'9")

* DRIVE

Each track is driven by an independent, high-torque, axial piston motor through planetary reduction gears. Two levers control provide smooth travel or counter-rotation upon demand.

• Travel speed (High/Low)	4.6/2.6 km/h (2.9 / 1.6 mph)
• Maximum traction force	4,500/2,400 kgf (9,920 / 5,291 lbf)
• Maximum grade	3° / 58%

* WEIGHT

Boom 2,405 mm (7'11") / Arm 1,200 mm (3'11") / Bucket SAE 0.11 m³ (0.14 yd³)

Shoe Width	Operating Weight	Ground Pressure
300mm(1')	3,660 kg (7,937 lb)	0.33kgf/cm ² (32 kpa, 4.6 psi)

* BUCKET

Capacity		Width		Weight	Recommendation	
					2,405mm (7'11") Boom	
PCSA, heaped	CECE heaped	Without side cutters	With side cutters		1,200mm (3'11") Arm	1,330mm (4'4") Arm
0.11m ³ (0.14yd ³)	0.094m ³ (0.12yd ³)	550mm (1'10")	576mm (1'11")	90 kg (198 lb)	B	B

A. Suitable for materials with density of 2,000 kg/m³ (3,370 lb/CU · yd) or less
B. Suitable for materials with density of 1,600 kg/m³ (2,700 lb/CU · yd) or less
C. Suitable for materials with density of 1,100 kg/m³ (1,850 lb/CU · yd) or less

* UNDERCARRIAGE

Tractor type undercarriage. Heavy duty track frame, all welded stress-relieved structure. Top grade materials are used for toughness. Side frames are welded, securely and rigidly to the track frame. Lifetime-lubricated track rollers, idlers with floating seals. Hydraulic track adjusters with shock-absorbing recoil springs.

• Number of rollers and shoes (each side)	
Lower rollers	4
Track shoes	Rubber shoe
Overall track length	2,123mm(7')
Shoe width	300mm(1')

* REFILL CAPACITIES

• Fuel tank	42 ℓ (11.1 US gal, 9.2 lmp gal)
• Cooling system (Radiator capacity)	5 ℓ (1.3 US gal, 1.1 lmp gal)
• Engine oil	6.3 ℓ (1.7 US gal, 1.4 lmp gal)
• Final drive (each)	0.5 ℓ (0.1 US gal, 0.1 lmp gal)
• Hydraulic system	45 ℓ (11.9 US gal, 9.9 lmp gal)
• Hydraulic tank	40 ℓ (10.6 US gal, 8.8 lmp gal)

DIMENSIONS & WORKING RANGES

* DIMENSIONS

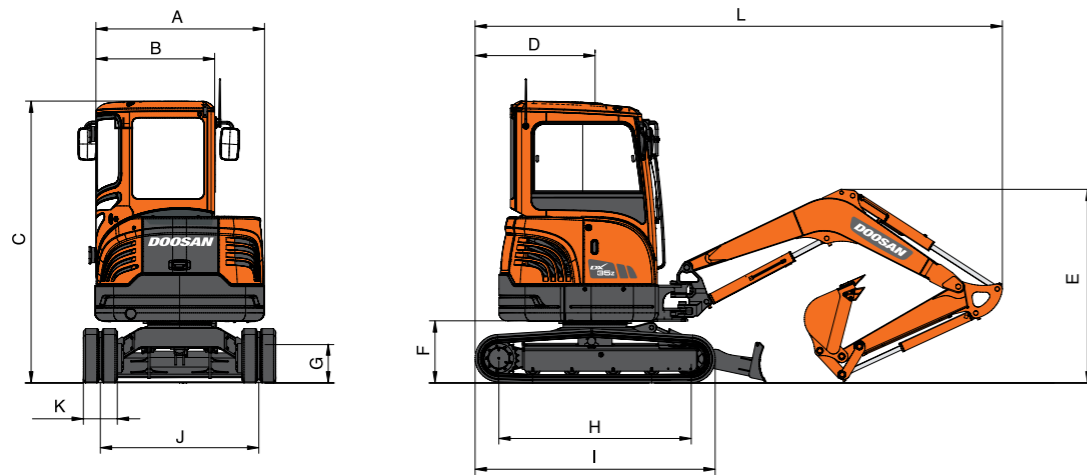

Boom type	2,405mm(7'11")
Arm type	1,200mm(3'11")
A Overall width of upper structure	1,500mm(4'11")
B Overall width of cab	1,030mm(3'5")
C Overall height of cab	2,515mm(8'3")
D Tail swing radius	1,060mm(3'6")
E Overall height	1,720mm(5'8")
F Clearance under counterweight	576mm(1'11")
G Ground Clearance	310mm(1')
H Tumbler distance	1,700mm(5'7")
I Track length	2,123mm(7')
J Track gauge	1,400mm(4'7")
K Track shoe width	300mm(1')
L Overall length	4,645mm(15'3")

* DIGGING FORCE (ISO)

Bucket (PCSA)	0.11m ³	
Digging force	3,010 kgf	
	29.5 kN	
Digging force	6,636 lbf	
Arm	1,200mm	1,330mm
Digging force	2,140 kgf	1,960 kgf
	20.99 kN	19.22 kN
	4,718 lbf	4,321 lbf

* WORKING RANGE

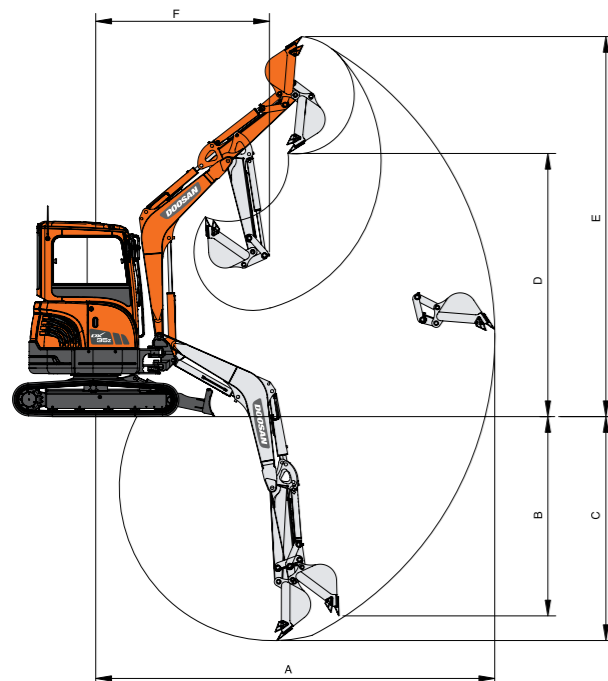

Boom type	2,405mm(7'11")	
Arm type	1,200mm (3'11")	1,330mm (4'4")
Bucket type (SAE)	0.11m ³ (0.14yd ³)	0.11m ³ (0.14yd ³)
A Max. Digging Reach	5,090mm (16'8")	5,200mm (17'1")
B Max. Vertical Wall Depth	2,560mm (8'5")	2,630mm (8'8")
C Max. Digging Depth	3,025mm (9'11")	3,155mm (10'4")
D Max. Loading Height	3,350mm (11')	3,410mm (11'2")
E Max. Digging Height	4,840mm (15'11")	4,880mm (16')
F Min. Swing Radius	2,210mm (7'3")	2,060mm (6'9")

LIFTING CAPACITY

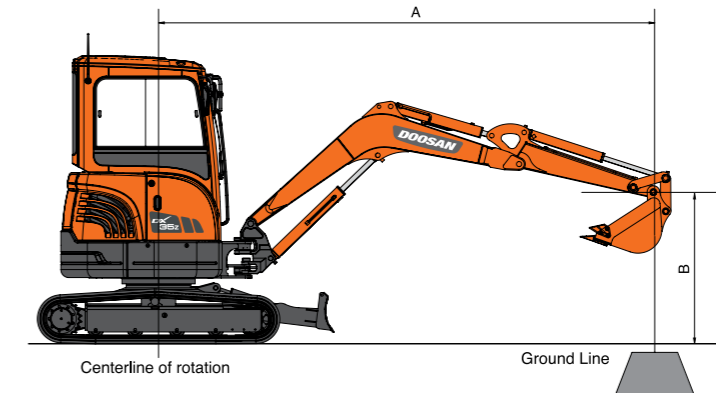

[Dozer up]

Metric Boom : 2,405mm(7'11") Arm : 1,200mm(3'11") Bucket : SAE 0.11m³(0.14yd³) CECE 0.094m³(0.12yd³) Shoe : 300mm(1') Unit : 1,000kg

A(m)	2		3		4		Max. Reach		A(m)
B(m)	☺	☹	☺	☹	☺	☹	☺	☹	
4							*0.77	*0.77	2.76
3			*0.67	*0.67			0.48	0.47	3.76
2			0.70	0.69	0.43	0.42	0.39	0.38	4.21
1			0.67	0.65	0.42	0.41	0.36	0.36	4.34
O (Ground)	1.23	1.18	0.64	0.63	0.41	0.40	0.38	0.38	4.18
-1	1.25	1.20	0.64	0.63			0.47	0.46	3.68
-2	1.30	1.25					*0.84	0.83	2.59

Feet

Unit : 1,000lb

A(ft)	6		8		10		12		14		Max. Reach		A(ft)
B(ft)	☺	☹	☺	☹	☺	☹	☺	☹	☺	☹	☺	☹	
12					1.54	1.51					1.41	1.38	10'6"
10					*1.48	*1.48	1.12	1.10			1.08	1.06	12'3"
8					1.54	1.51	1.12	1.10			0.92	0.91	13'4"
6			2.16	2.10	1.50	1.47	1.11	1.09			0.84	0.83	13'12"
4			2.04	1.99	1.45	1.42	1.08	1.06	0.83	0.82	0.81	0.79	14'3"
2			1.97	1.92	1.41	1.37	1.06	1.04	0.82	0.81	0.81	0.79	14'2"
O (Ground)			1.95	1.90	1.38	1.35	1.04	1.02			0.84	0.83	13'9"
-2	3.20	3.07	1.95	1.90	1.38	1.35	1.04	1.02			0.94	0.92	12'11"
-4	3.25	3.12	1.98	1.92	1.39	1.36					1.13	1.10	11'6"
-6	3.32	3.19	2.03	1.97							1.59	1.56	9'4"

Metric Boom : 2,405mm(7'11") Arm : 1,330mm(4'4") Bucket : SAE 0.11m³(0.14yd³) CECE 0.094m³(0.12yd³) Shoe : 300mm(1') Unit : 1,000kg

A(m)	2		3		4		Max. Reach		A(m)
B(m)	☺	☹	☺	☹	☺	☹	☺	☹	
4							*0.71	*0.71	2.95
3							0.46	0.45	3.89
2			0.71	0.69	0.43	0.42	0.37	0.36	4.33
1			0.67	0.65	0.42	0.40	0.35	0.34	4.45
O (Ground)	1.22	1.18	0.64	0.62	0.41	0.40	0.36	0.36	4.30
-1	1.24	1.19	0.64	0.62			0.44	0.43	3.82
-2	1.28	1.24					0.74	0.73	2.80

Feet

Unit : 1,000lb

A(ft)	6		8		10		12		14		Max. Reach		A(ft)
B(ft)	☺	☹	☺	☹	☺	☹	☺	☹	☺	☹	☺	☹	
12					*1.39	*1.39					1.30	1.28	11'0"
10					1.55	1.52	1.13	1.11			1.02	1.00	12'8"
8					1.55	1.52	1.13	1.11			0.88	0.86	13'8"
6			2.17	2.11	1.50	1.47	1.11	1.09	0.84	0.83	0.80	0.79	14'4"
4			2.06	2.00	1.45	1.42	1.08	1.06	0.83	0.81	0.77	0.76	14'7"
2			1.97	1.92	1.40	1.37	1.06	1.03	0.82	0.80	0.77	0.75	14'6"
O (Ground)	*2.55	*2.55	1.94	1.89	1.37	1.34	1.04	1.02	0.81	0.80	0.80	0.79	14'1"
-2	3.17	3.05	1.94	1.89	1.37	1.34	1.03	1.01			0.88	0.87	13'3"
-4	3.22	3.09	1.96	1.90	1.38	1.35					1.05	1.03	11'12"
-6	3.29	3.16	2.00	1.95							1.43	1.40	9'12"

- The load point is a hook located on the back of the bucket.
- * Rated loads are based on hydraulic capacity.
- Rated loads do not exceed 87% of hydraulic capacity or 75% of tipping capacity.

☺ : Rating Over Front
☹ : Rating Over Side or 360 degree

LIFTING CAPACITY

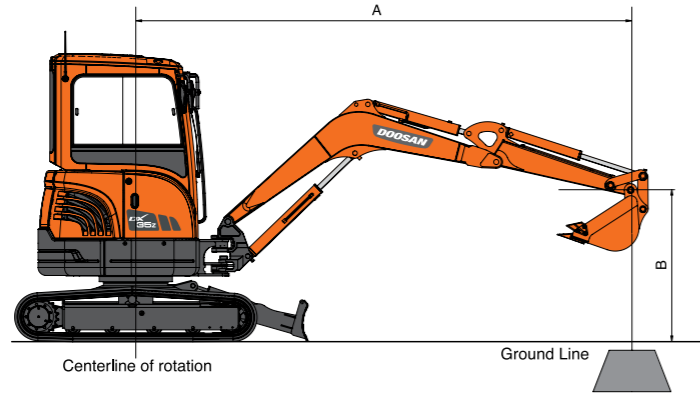

[Dozer Down]

Metric Boom : 2,405mm(7'11") Arm : 1,200mm(3'11") Bucket : SAE 0.11m³(0.14yd³) CECE 0.094m³(0.12yd³) Shoe : 300mm(1') Unit : 1,000kg

A(m)	2		3		4		Max. Reach		A(m)
B(m)	☺	☹	☺	☹	☺	☹	☺	☹	
4							*0.77	*0.77	2.76
3			*0.67	*0.67			*0.73	0.47	3.76
2			*0.88	0.69	*0.75	0.41	*0.74	0.38	4.21
1			*1.18	0.65	*0.84	0.40	*0.78	0.36	4.34
O (Ground)	*1.29	1.18	*1.34	0.63	*0.89	0.39	*0.82	0.38	4.18
-1	*2.17	1.20	*1.26	0.63			*0.87	0.46	3.68
-2	*1.31	1.25					*0.84	0.83	2.59

Feet

Unit : 1,000lb

A(ft)	6		8		10		12		14		Max. Reach		A(ft)
B(ft)	☺	☹	☺	☹	☺	☹	☺	☹	☺	☹	☺	☹	
12					*1.56	1.51					*1.64	1.38	10'6"
10					*1.48	*1.48	*1.58	1.10			*1.61	1.06	12'3"
8					*1.67	1.51	*1.59	1.10			*1.62	0.91	13'4"
6			*2.61	2.10	*2.02	1.47	*1.75	1.09			*1.65	0.83	13'12"
4			*3.46	1.99	*2.42	1.42	*1.96	1.06	*1.71	0.82	*1.70	0.79	14'3"
2			*3.97	1.92	*2.74	1.37	*2.13	1.04	*1.78	0.81	*1.75	0.79	14'2"
O (Ground)			*4.08	1.90	*2.89	1.35	*2.22	1.02			*1.81	0.83	13'9"
-2	*4.42	3.07	*3.93	1.90	*2.85	1.35	*2.16	1.02			*1.88	0.92	12'11"
-4	*5.07	3.12	*3.51	1.92	*2.56	1.36					*1.93	1.10	11'6"
-6	*3.77	3.19	*2.62	1.97							*1.91	1.56	9'4"

Metric Boom : 2,405mm(7'11") Arm : 1,330mm(4'4") Bucket : SAE 0.11m³(0.14yd³) CECE 0.094m³(0.12yd³) Shoe : 300mm(1') Unit : 1,000kg

A(m)	2		3		4		Max. Reach		A(m)
B(m)	☺	☹	☺	☹	☺	☹	☺	☹	
4							*0.71	*0.71	2.95
3							*0.69	0.45	3.89
2			*0.82	0.69	*0.71	0.42	*0.71	0.36	4.33
1			*1.14	0.65	*0.81	0.40	*0.74	0.34	4.45
O (Ground)	*1.46	1.18	*1.33	0.62	*0.88	0.40	*0.79	0.36	4.30
-1	*2.26	1.19	*1.28	0.62			*0.85	0.43	3.82
-2	*1.49	1.24					*0.86	0.73	2.80

Feet

Unit : 1,000lb

A(ft)	6		8		10		12		14		Max. Reach		A(ft)
B(ft)	☺	☹	☺	☹	☺	☹	☺	☹	☺	☹	☺	☹	
12					*1.39	*1.39					*1.52	1.28	11'0"
10					*1.35	*1.35	*1.45	1.11			*1.51	1.00	12'8"
8					*1.55	1.52	*1.50	1.11			*1.53	0.86	13'8"
6			*2.40	2.11	*1.99	1.47	*1.67	1.09	*1.57	0.83	*1.57	0.79	14'4"
4			*3.28	2.00	*2.32	1.42	*1.89	1.06	*1.66	0.81	*1.62	0.76	14'7"
2			*3.87	1.92	*2.67	1.37	*2.08	1.03	*1.75	0.80	*1.68	0.75	14'6"
O (Ground)	*2.55	*2.55	*4.07	1.89	*2.86	1.34	*2.20	1.02	1.76	0.80	*1.74	0.79	14'1"
-2	*4.37	3.05	*3.98	1.89	*2.87	1.34	*2.18	1.01			*1.82	0.87	13'3"
-4	*5.34	3.09	*3.63	1.90	*2.64	1.35					*1.89	1.03	11'12"
-6	*4.16	3.16	*2.87	1.95							*1.92	1.40	9'12"

1. The load point is a hook located on the back of the bucket.
 2. * Rated loads are based on hydraulic capacity.
 3. Rated loads do not exceed 87% of hydraulic capacity or 75% of tipping capacity.

☺ : Rating Over Front
 ☹ : Rating Over Side or 360 degree

STANDARD AND OPTIONAL EQUIPMENT

* STANDARD EQUIPMENT

• Cabin & Interior

- All weather sound suppressed type cab
- Adjustable suspension seat
- Pull-up type front window and removable lower front window
- Room light
- Cigarette lighter
- Cup holder
- Heater and defroster
- Fresh air filter
- Storage box

• Others

- Double element air cleaner
- Water separator
- Alternator (12V, 40 amps)
- Electric horn
- Halogen working lights (Boom mounted 1)
- Piping for hammer (One way) and for rotation (Two way)
- Rubber shoe
- Maintenance free battery

• Safety

- ROPS & TOPS Cabin
- Hydraulic safety lock lever
- Safety glass
- Hammer for emergency escape

* OPTIONAL EQUIPMENT

• Safety

- ROPS & TOPS Canopy (4-Pillar)
- Rotating beacon
- Accumulator (Pilot pressure control)
- Travel alarm
- Side mirror

• Others

- Track guards (Front)
- Halogen working light
 - Boom mounted 2
 - Cabin mounted 2
- Piping for quick clamp
- Lever pattern changing valve
- Air-conditioner

