

DOOSAN

Construction Equipment

DX160W

Engine Power	SAE J1349, net 99 kW (132 HP) @ 2,000 rpm
Operational Weight	14,750 ~ 15,250 kg (32,518 ~ 34,303 lb)
Bucket Capacity (SAE/PCSA)	0.24 ~ 0.76 m ³ (0.31 ~ 0.99 yd ³)



DOOSAN DX160W HYDRAULIC EXCAVATOR : A NEW MODEL WITH NOVEL FEATURES

DX 160W



THE NEW DX160W HYDRAULIC EXCAVATOR HAS ALL THE ADVANTAGES OF THE PREVIOUS MODEL, AND NOW OFFERS ADDITIONAL ADDED VALUE TO THE OPERATOR.

The new DX160W was developed with the concept of “providing optimum value to the end user.” In concrete terms, this translates, into :

INCREASED PRODUCTION AND IMPROVED FUEL ECONOMY are attributed to the electronic optimization of the hydraulic system and the new generation DOOSAN engine (Tier II/ Stage II).

IMPROVED ERGONOMICS, increases comfort and excellent all round visibility ensuring a safe and pleasant working environment.

IMPROVED RELIABILITY, is achieved through the use of high performance materials combined with new methods of structural stress analysis, and leads to increased component life expectancy, thus reducing running costs.



ADVANCED H-CLASS BUCKET

- Doosan new H-class bucket has the best strength of steel & the optimized design
- Add side cutter / add chamfer and inner plate at member part
- Increase bucket solidity and change casting type



ADVANCED FRONT BUSH

- EM bushing (Enhanced Macro-surface)
- Pocket & Dimple surface pattern : Optimized greasing & Trap foreign object
- Wear resistant solid lubricant coating : Noise free & enhanced anti-seizure property
- 30% longer life time than competitors



ADVANCED HD CABIN (OPTIONAL)

- ROPS, FOPS optional
- The latest interior (MP3, Joystick, Air suspension seat, etc.)



7 INCH MONITOR

- New, user-friendly LCD color monitor with full access to machine settings and maintenance data.
- Operator can see rear view through new monitor (If customer selects rear view camera option)



TROPICAL HYDRAULIC OIL (ISO VG 68)

- Maintain best performance of your machine by keeping optimum viscosity in tropical area.





PERFORMANCE & PRODUCTIVITY

DX160W

The performance of the DX160W has a direct effect on its productivity. Its new EPOS™ controlled hydraulic system have combined to create an unbeatable hydraulic excavator, with a cost/performance ratio that makes the DX160W even more appealing.



DOOSAN ENGINE(DB58)

Doosan product gives high performance through in-house engine.

Doosan engine(In-house) perfectly harmonized with the hydraulic system and provides strong power. Mechanical engine provides high resistance to moisture, dust, and bad fuel quality. The best engine power in the industry(132HP) provides stable working speed even in the heavy workload situation.

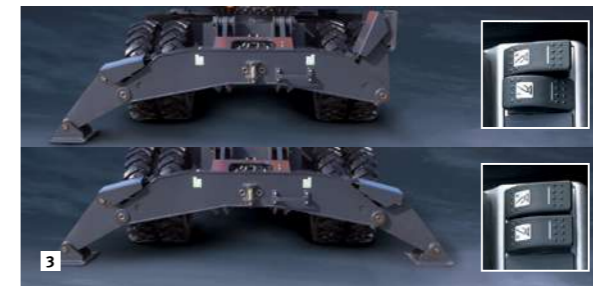
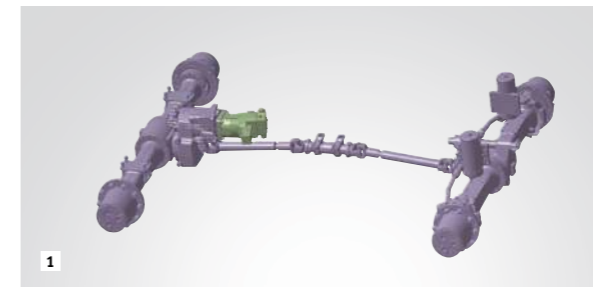
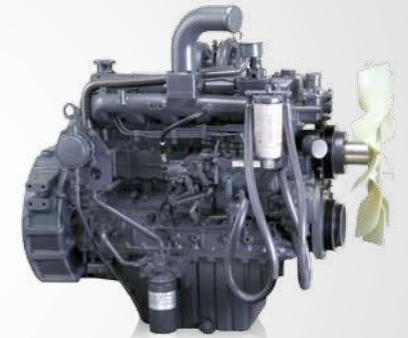

1 NEW DRIVE LINE CONCEPT

The new travel motor and transmission control in the drive line provide comfortable travel due to increased smoothness, improved hydraulic retarding and improved gear shifting.

HEAVY DUTY AXLES

The front axle offers wide oscillating and steering angles. The transmission is mounted directly on the rear axle for protection and optimum ground clearance.

ADVANCED DISC BRAKE SYSTEM

The new disc brake system works directly on the hub instead of the drive shaft to avoid planetary gear backlash. This eliminates the rocking effect associated with working free on wheels. The new axle is designed for low maintenance and the oil change intervals have been increased from 1,000 to 2,000 hours further reducing owning and operating costs.

EXCAVATOR CONTROL

Improved Excavator control by New EPOS™ system The brains of the hydraulic excavator, the EPOS™ (Electronic Power Optimizing system), have been improved, through a CAN (Controller Area Network) communication link, these units are now perfectly synchronised.

2 UNDERCARRIAGE DESIGN

A rigid, welded frame provides excellent durability. Efficient hydraulic lines routing, transmission protection and heavy duty axles make the undercarriage perfect for wheel excavator applications. Both outriggers and dozer blade are pin type for maximum flexibility. An optional work tool restraint bar is available.

3 OUTRIGGERS

The pin type design allows the outriggers to be mounted on the front and/or rear for maximum operating stability when digging or lifting and are individually controlled for leveling on slopes.

4 DOZER BLADE

The pin type design allows the dozer blade to be mounted on the front and/or rear and is used for leveling, clean-up work and for stabilizing the machine during digging applications. The large dozer bottom and parallel design provide minimized ground pressure.

HYDRAULIC PUMP

Considering the property of wheel excavator that intensively performs traveling operation, bent axis piston pump is adopted for its high efficiency and excellent response in high pressure. The Main pump has a capacity of 2x156.1l/min(@ 2,000rpm) reducing cycle time while a high capacity gear pump improves pilot line efficiency.

SWING DRIVE

Shocks during rotation are minimized, while increased torque is available to ensure rapid cycles.





DURABILITY & RELIABILITY

DX160W

The reliability of an item of plant contributes to its overall lifetime operating costs. DOOSAN uses computer-assisted design techniques, highly durable materials and structures then test these under extreme conditions. Durability of materials and longevity of structures are our first priorities.



D-TYPE FRAME

The D-type frame and chassis frame add strength and minimize distortion due to shocks.

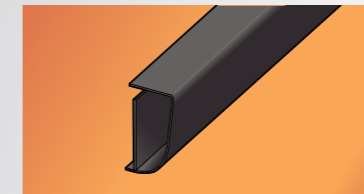

STRESS ANALYSIS DESIGN (FEM) AND INNOVATIVE MANUFACTURING TECHNIQUE PROVIDES A STRONG AND STABLE UNDERCARRIAGE

The Chassis Frame, Outrigger Assembly and Dozer Blade have been designed by interpretative techniques and reliability testing using 3 dimension CAD tools, to ensure improved durability and reliability.



1 ADVANCED BUSHING

A highly lubricated metal is used for the boom pivot in order to increase the lifetime and extend the greasing intervals to 250 hours. A rolled bushing, with very fine grooves, has been added to the arm, bucket, dozer, and outrigger pivot; so greasing is only required every 50 hours.

2 POLYMER SHIM

A polymer shim is added to the bucket, dozer, and outrigger pivot to promote extended pin and bushing life.

3 DOZER & OUTRIGGER CYLINDERS PROTECTION COVERS

Large reinforced protective covers have been adopted to completely protect the Dozer & Outrigger cylinders from falling stones etc, while the machine is operating.

4 CAST COUNTERWEIGHT

A Cast Counterweight has been adopted to minimize deformation by external impact. In addition, operating stability has been increased by use of a low center of gravity design.

5 LED (LUMINESCENT DIODE) TYPE STOP LAMPS

The use of LED type Stop Lamps ensures considerably improved average service life compared to the existing standard filament bulbs. Furthermore, the faster lighting speed helps contribute to accident prevention.



RELIEF CUTOFF

The pump continues to supply flow even when the maximum pressure on the system is reached due to severe working environments and large workloads. Relief cutoff technology of DX160W prevents transfer of unnecessary flow to maintain powerful working level at the maximum value while reducing consumption of fuel.

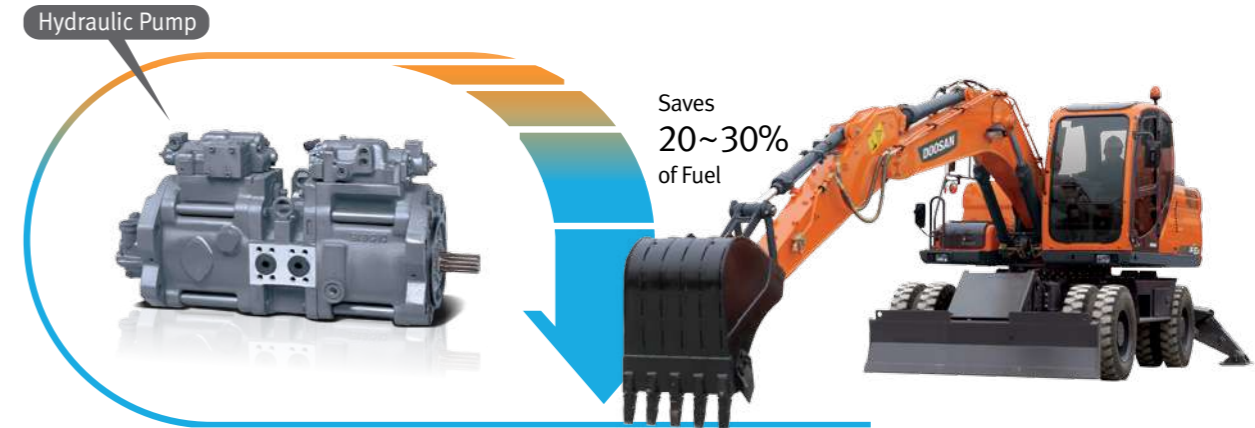

OPTIMIZED LEVER CONTROL & AUTO IDLE

When operator takes a break and leaves the control joystick fixed, both of the engine and the pump are kept in standby mode and prevents unnecessary fuel consumption.



PUMP MATCHING TECHNOLOGY

Engine & pump matching, the new technology of Doosan, fully resolves problems; low responses time of the system, unnecessary fuel consumption. Matching response time between pump and engine efficiently reduces unnecessary fuel consumption as well as exhaust fumes.

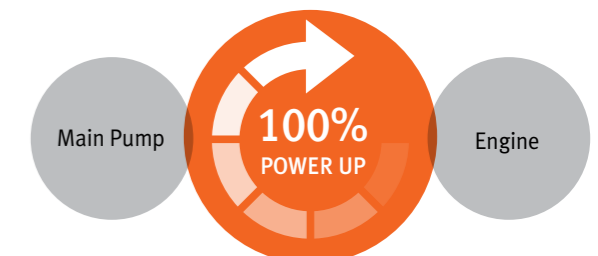
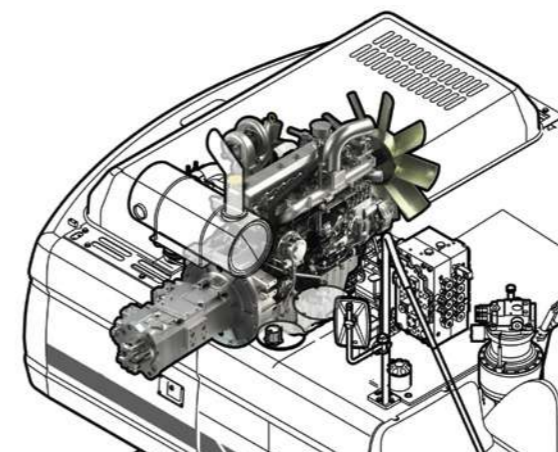



OPERATOR COMFORT

DX160W

The work rate of the hydraulic excavator is directly linked to the performance of its operator. DOOSAN designed the DX160W by putting the operator at the centre of the development goals. The result is significant ergonomic value that improves the efficiency and safety of the operator.



MONITOR



- 3 power modes for maximum efficiency
 - Power mode
 - Standard mode
 - Economy mode
- 3 work modes to suit your application
 - 1-way mode
 - 2-way mode
 - Digging mode

- 1 Control panel
- 2 Navigation modes
 - Rearview camera, Display selector
- 3 Working modes
 - Auto-idle & Flow rate control

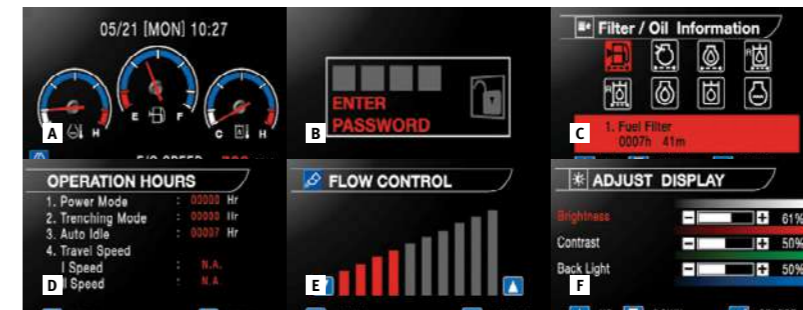

CONTROL PANEL

- A Standard screen
- B Anti-theft protection
- C Filter/oil information
- D Operation history
- E Flow rate control
- F Contrast control

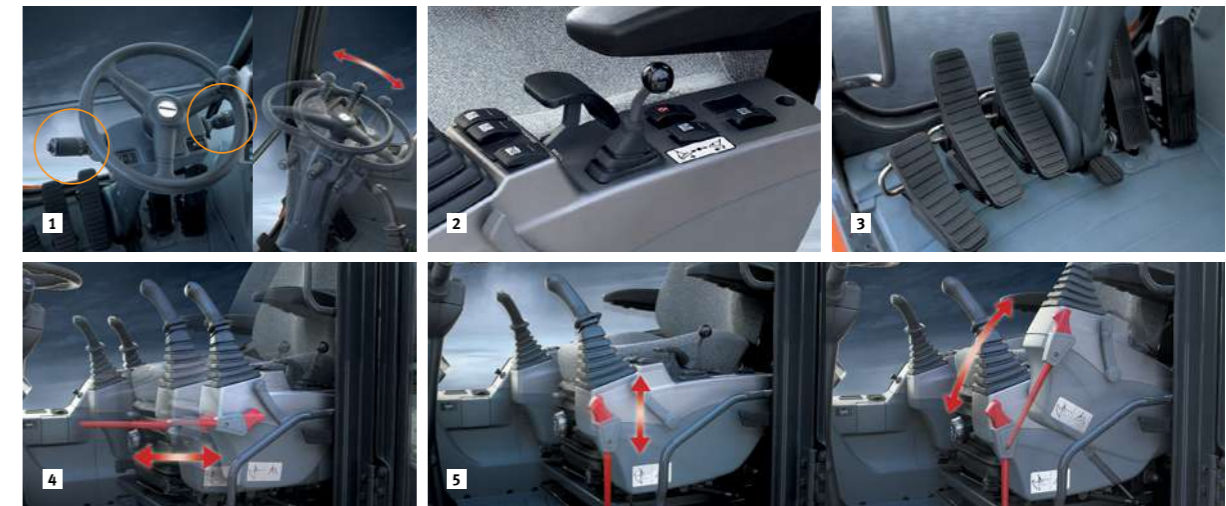

1 STEERING COLUMN

The Forward/Neutral/Reverse & gear selection switch is mounted on the steering column to minimize operator movements while traveling so that safety and operator comfort are ensured. The lower part of Steering Column can be tilted for improved operator comfort.

2 DOZER/OUTRIGGER CONTROL

The Dozer/Outrigger Control Lever, combined with the associated switches, allows for the operator to select between any combination of independent or simultaneous operation of the dozer/ Outriggers.

3 FOOT PEDALS

The position of the Option, Brake and Accelerator Pedal have been set by ergonomic analysis to maximise operating efficiency while minimizing foot movement. The required pedal operating forces have also been decreased to reduce fatigue.

4 COMFORTABLE 2-STAGE SLIDING SEAT

5 CONTROL STAND (TELESCOPIC & TILTING FUNCTION)

AIR CONDITIONING

The high performance air conditioning provides an air flow which is adjusted and electronically controlled for the conditions. Five operating modes enable even the most demanding operator to be satisfied.



CONTROL LEVER

Very precise control of the equipment increases versatility, safety and facilitates tricky operations requiring great precision. Leveling operations and particularly the movement of suspended loads are made easier and safer. The control levers have additional electrical buttons for controlling other additional equipment (for example, grabs, crushers, grippers, etc.)

AIR SUSPENSION SEAT (OPTIONAL)

An Air Suspension Seat is available as an option, which further reduces any vibration being transmitted to the operator while working or travelling. In addition, this option is fitted with a heating system for operator comfort in cold weather.





EASY MAINTENANCE

DX160W

Short maintenance operations at long intervals increase the availability of the equipment on site. DOOSAN has developed the DX160W with a view to high profitability for the user.



REMARKABLE ELONGATION OF CONSUMABLES REPLACEMENT

Very economic thanks to remarkable elongation of consumables replacement

- Engine oil, engine oil filter 500 hours
- Return filter 1,000 hours
- Hydraulic fluid 2,000 hours
- Air cleaner 2,000 hours

* The replacement interval depends on oil grade.

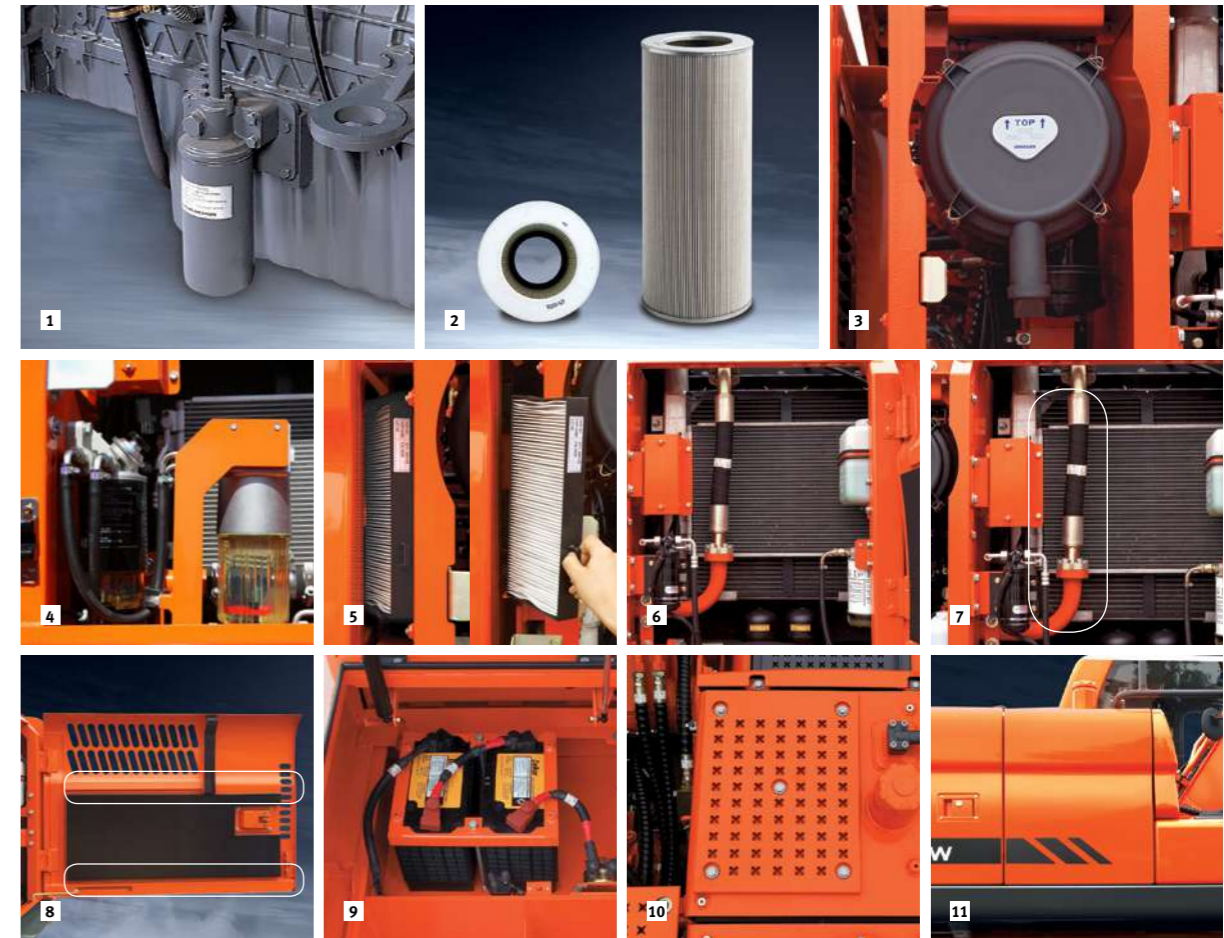
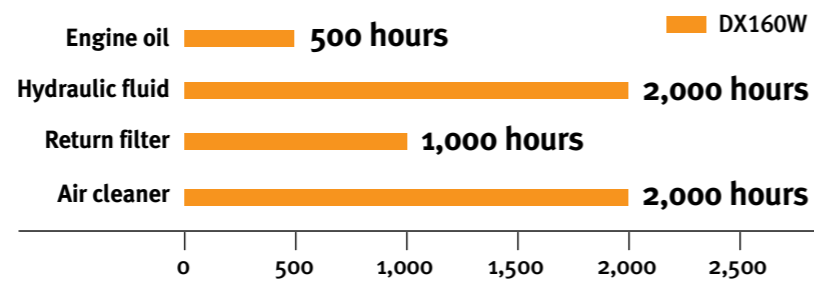

1 ENGINE OIL FILTER

The engine oil filter offers a high level of filtration allowing the oil change interval to be increased to 500 hours. It is easy to access and is positioned to avoid contaminating the surrounding environment.

2 HYDRAULIC OIL RETURN FILTER

The protection of the hydraulic system is made more effective by the use of glass fiber filter technology in the main oil return filter. This means that with more than 99.5% of foreign particles filtered out, the oil change interval is increased.

3 AIR CLEANER

The large capacity forced air cleaner removes over 99% of airborne particles, reducing the risk of engine contamination and making the cleaning and cartridge change intervals greater.

4 WATER SEPARATOR

High efficiency and large capacity water separator protect the engine by removing most moisture from the fuel.

5 AIR-CONDITIONER FILTER

Since independent air-conditioner filter for internal and external machine, fresh air is supplied indoors.

6 RADIATOR AND OIL COOLER

Radiator and oil cooler in high capacity and high efficiency are attached so that the best cooling function can be maintained all the time.

7 APPLYING STAINLESS TUBE

Stainless tube is applied to oil cooler piping to prevent oil leakage.

8 SOLID SIDE DOOR

The muscular appearance and internal reinforced board in attachment type realize both good appearance and solid strength.

9 BATTERY COVER

As battery cover is applied, shor tage is prevented and customer is protected from unexpected accident.

10 PUNCHING COVER IN ASTERISK SHAPE

As anti-skid cover punched in asterisk shape is added on the upper part, slippery is prevented for service to increase safety.

11 FUEL TANK IN HIGH CAPACITY

Thanks to the fuel tank with the maximum capacity of 280 liter in the same grade, consecutive work time is elongated.

TELEMATICS SERVICE (OPTIONAL)

GLOBAL PARTS NETWORK

TELECOMMUNICATIONS

Data flow from machine to web



TELEMATICS SERVICE TERMINAL

Telematics Service terminal is installed to machine / connected to EPOS™



TELECOMMUNICATION

GPS, EPOS™ data is sent to designated server by GSM, Satellite telecommunication

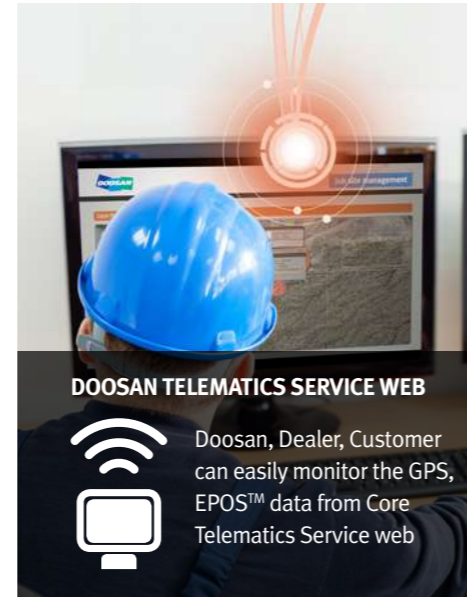

DOOSAN TELEMATICS SERVICE WEB

Doosan, Dealer, Customer can easily monitor the GPS, EPOS™ data from Core Telematics Service web

FUNCTIONS

Doosan Telematics Service provides various functions to support your great performance

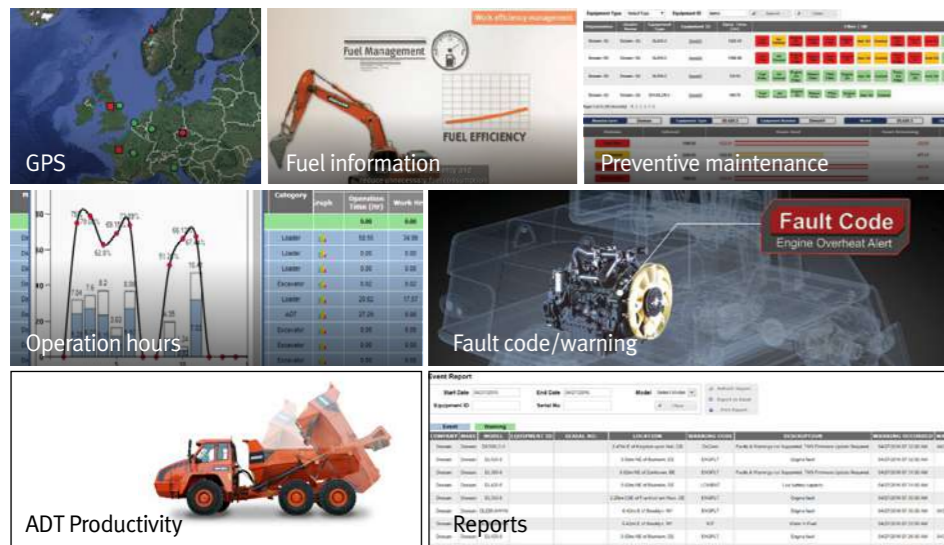

TELEMATICS SERVICE BENEFITS

Doosan and dealer support customers to improve work efficiency with timely and responsive services

Customer

- Improve work efficiency
- Timely and preventive service
- Improve operator's skills by comparing work pattern
- Manage fleet more effectively

Dealer

- Better service for customers
- Provide better quality of service
- Maintain machine value
- Better understanding of market needs

Doosan

- Responsive to customer's voice
- Utilize quality-related field data
- Apply customer's usage profile to developing new machine

GLOBAL PDC (PARTS DISTRIBUTION CENTER) NETWORK

Doosan provides fast and precise worldwide delivery of genuine Doosan parts through its global PDC (parts distribution center) network.

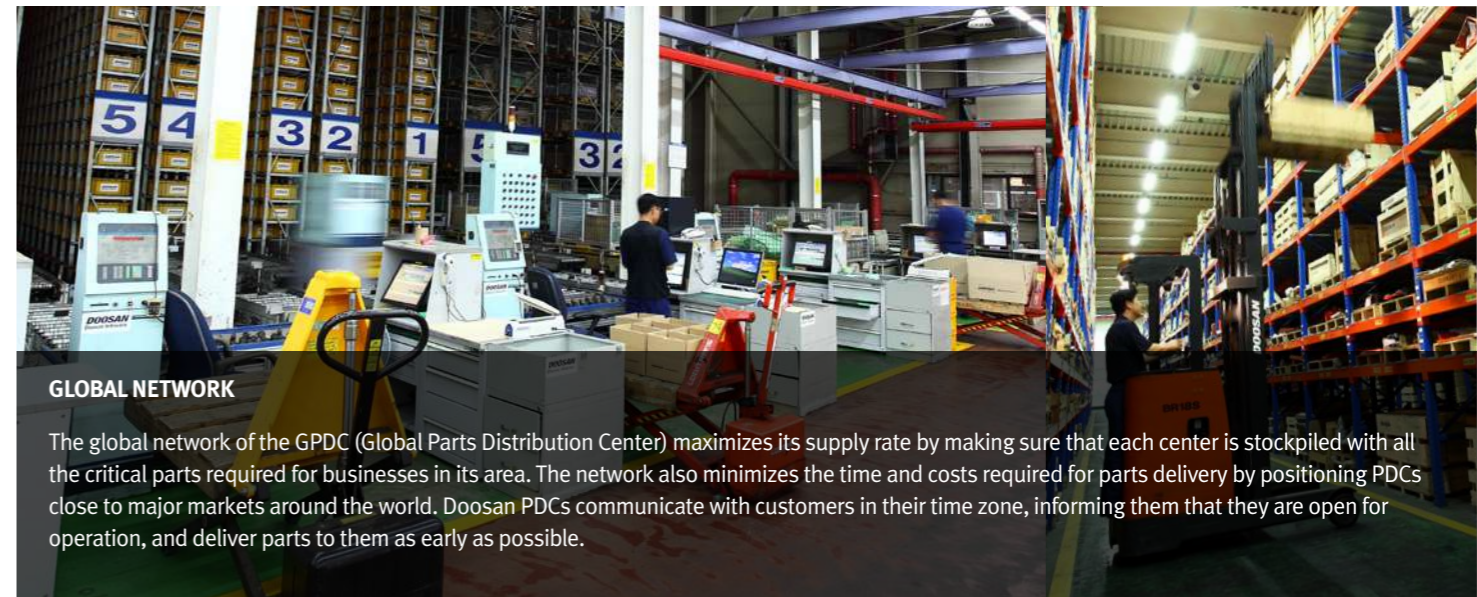

GLOBAL NETWORK

The global network of the GPDC (Global Parts Distribution Center) maximizes its supply rate by making sure that each center is stockpiled with all the critical parts required for businesses in its area. The network also minimizes the time and costs required for parts delivery by positioning PDCs close to major markets around the world. Doosan PDCs communicate with customers in their time zone, informing them that they are open for operation, and deliver parts to them as early as possible.

The Global Parts Distribution Center Network

PDCs had been set up as shown below, including Mother PDC in Ansan, Korea. The seven other PDCs include one in China (Yantai), one in the USA (Chicago), one in Brazil (Campinas), two in Europe (Germany and the UK), one in the Middle East (Dubai), and one in Asia (Singapore).



MPDC : Mother Parts Distribution Center PDC : Parts Distribution Center

FUNCTION	EXCAVATOR	WHEEL LOADER	ADT
GPS	All models	All models	All models
E-mail reports	All models	All models	All models
Operation hours	All models	All models	All models
Maintenance parts	All models	Tier 4 only	All models
Fault code/ Warning	All models	Tier 4 only	All models
Fuel information	All models	Tier 4 only	All models
Dump capacity	N/A	N/A	All models

PDC BENEFIT

- Distribution Cost Reduction
- Maximum Parts supply rate
- Shortest distance/time parts delivery
- Real-time service support
- Minimum downtime

Heavy Construction Bucket, which is also called Heavy Duty bucket, is the most commonly used bucket in the construction equipment market and is designed mainly for use in heavy construction but also used in low density mining and quarry application.

Hinge
Optimized reinforced construction for high strength and performance matched to the machine's power.

Adapter
Corner adapter Positioned under Side cutter to increase strength.

Wrapper (Shell)
Shape increases heel clearance and decreases wear rate.

Horizontal Bottom Wear Plates
Protects bottom section and reinforces bucket for greater strength and rigidity. Designed for easily replacement during maintenance repair.

Lip Plate (Cutting Edge)
Beveled edge for better penetration and 500BHN material for high abrasion resistance.

Tooth (Tip)
Designed with mechanical properties that maintain hardness for long wear life in tough digging applications.

Side cutter
Designed for better penetration and used high wear resistant material.

Side Wear Plates
Side plates meet up with bottom wear plates for seamless corner protection.



General Purpose bucket

which is also called General Purpose bucket, is designed for digging and re-handling soft to medium materials e.g. materials with low wear characteristics such as top-soil, loam, coal.



Heavy Duty bucket

which is also called Heavy Duty bucket, is the most commonly used bucket in the construction equipment market and is designed mainly for use in heavy construction but also used in low density mining and quarry application.



Severe Duty bucket

which is also called Severe Duty bucket. The bucket is designed for use in high density mining and quarry application using high strength and high abrasion resistance materials. It can be used in the toughest of applications.



Extra Severe Duty Bucket

which is also called X class bucket. The bucket is designed for use in high density mining and quarry application using high strength and high abrasion resistance materials. It can be used in the toughest of applications.

TOOTH

GD (General Duty) Tooth
Optimized design for Doosan's GP and the new General Construction bucket. Suitable for machines ranging from 14 to 70 tons. Recommended for general construction and utility loading applications.

HD (Heavy Duty) Tooth
Optimized design for the Heavy Construction bucket. Suitable for machines ranging from 14 to 70 tons. Recommended for most applications including excavating, trenching, loading and medium density quarries and mining.

SD (Severe Duty) Tooth
Optimized design for the Severe Mining bucket and the Xtreme Mining bucket. Suitable for machines ranging 22 to 70 tons. Recommended for extremely tough quarries and mining application.

BUCKET



General Purpose Bucket Heavy Duty Bucket

	Capacity (SAE/PCSA)
GENERAL PURPOSE BUCKET	0.24 / 0.39 / 0.45 / 0.51 / 0.59 / 0.64 / 0.76 m ³
HEAVY DUTY BUCKET	0.21 / 0.31 / 0.42 / 0.52 / 0.60 / 0.67 / 0.74 m ³

DEMOLITION



Hydraulic Breaker Fixed Pulverizer Rotating Crusher

	Model	Weight	Tool diameter	Frequency
HYDRAULIC BREAKER	DXB90H	1,000 kg	107 mm	820 BPM
	Model	Weight	Max. Jaw opening	Force at Tip
FIXED PULVERIZER	FP14	1,100 kg	680 mm	51 t
ROTATING CRUSHER	RC14	1,250 kg	720 mm	51 t

MATERIAL HANDLING



Multi-Grapple Stone Grapple Wood Grapple Log Grapple Orange Grapple

	Model	Weight	Max Jaw opening	Max. Closing Force	Capacity	
MULTI-GRAPPLE	MG14	1,050 kg	1,744 mm	4.6 t	0.45 m ³	
STONE GRAPPLE	SG14	761 kg	1,800 mm	-	0.34 m ²	
WOOD GRAPPLE	L / P	WG14	700 / 630 kg	1,800 mm	-	0.48 m ²
LOG GRAPPLE	L / P	LG14	835 / 810 kg	1,800 mm	-	0.42 m ²
ORANGE GRAPPLE	OG14	1,170 kg	1,890 mm	-	0.30 m ³	

L : Link type
P : Pendulum type

EARTH MOVING



Clamshell Bucket Plate Compactor Ripper

	Model	Weight	Max. Jaw opening	Capacity
CLAMSHELL BUCKET	CB14	900 kg	1,455 mm	0.37 m ³
	Model	Weight	Base plate (WxL)	Impulse force
PLATE COMPACTOR	PC14	804 kg	740 x 1,050 mm	6.4 t
	Model	Weight	Length	
RIPPER	RP14	245 kg	1,057 mm	

CONNECTING



Quick Coupler

	Model	Weight	Bucket Pin dia.	Working rage (Pin to Pin)
QUICK COUPLER	QC14	170 kg	65 mm	380 ~ 440 mm

TECHNICAL SPECIFICATIONS

ENGINE

Model	DOOSAN DB58TIS (Tier2)
Number of cylinders	6
Nominal flywheel power	99 kW(132HP) @ 2,000 rpm (SAE J1349, net)
Max torque	50 kgf.m(490 Nm) at 1,400 rpm
Piston displacement	5,890 cc (359 cu.in)
Bore & stroke	φ100 mm x 125 mm (3.9" X 4.9")
Starter	24 V / 4.5 kW
Batteries	2 x 12 V / 100 Ah
Air cleaner	Double element with auto dust evacuation.

HYDRAULIC CYLINDERS

The piston rods and cylinder bodies are made of high-strength steel. A shock absorbing mechanism is fitted in all cylinders to ensure shock-free operation and extend piston life.

[One-piece Boom]		
Cylinders	Quantity	Bore x Rod diameter x stroke
Boom	2	110 X 75 X 1,048mm(4.3" X 2.9" X 3'5")
Arm (short)	1	115 X 80 X 1,075mm(4.5" X 3.1" X 3'6")
Bucket	1	95 X 65 X 900mm(3.7" X 2.6" X 2'11")

WEIGHT

Operating weight, including 4,300 mm (14'1") one-piece boom, or 1,850+3,500 mm (6'1" + 11'6") two-piece boom, 2,100mm (6'11")arm, operator, lubricant, coolant, full fuel tank and the standard equipment. Weights are with 439kg (968 lb) bucket.

Undercarriage type		Operating weight (One-piece Boom)	Operating weight (Two-piece Boom)
Front attach	Rear attach		
Cradle	Dozer	13,750 kg (30,313 lb)	14,292 kg (31,508 lb)
Cradle	Outrigger	14,078 kg (31,036 lb)	14,620 kg (32,231 lb)
Dozer	Outrigger	14,658 kg (32,315 lb)	15,200 kg (33,510 lb)
Cradle	Dozer	14,685 kg (32,374 lb)	15,227 kg (33,569 lb)
Outrigger	Outrigger	15,013 kg (33,098 lb)	15,560 kg (34,292 lb)

HYDRAULIC SYSTEM

The heart of the system is the EPOS™ (Electronic Power Optimizing System). It allows the efficiency of the system to be optimized for all working conditions and minimizes fuel consumption. The new EPOS™ is connected to the engine electronic control via a data transfer link to harmonize the operation of the engine and hydraulics.

- The hydraulic system enables independent or combined operations.
- Cross-sensing pump system for fuel savings.
- Auto deceleration system.
- Two operating modes, two power modes.
- Button control of flow in auxiliary equipment circuits.
- Computer-aided pump power control.

Main pumps

2 variable displacement axial piston pumps
max flow: 2 x 156.1 l/min (2 X 41.2US gpm, 2 X 34.3 Imp gpm)

Pilot pump

Gear pump - max flow: 18.5 l/min (4.9US gpm, 4.1 Imp gpm)

Maximum system pressure

Boom/arm/Bucket :
- Normal mode: 330 kgf/cm²(324 bar)
- Power mode: 350 kgf/cm²(343 bar)
Travel: 350 kgf/cm²(343 bar)
Swing: 245 kgf/cm²(240 bar)

SWING MECHANISM

- An axial piston motor with two-stage planetary reduction gear is used for the swing.
- Increased swing torque reduces swing time.
- Internal induction-hardened gear.
- Internal gear and pinion immersed in lubricant bath.
- The swing brake for parking is activated by spring and released hydraulically.

Swing speed: 0 to 11.3 rpm

UNDERCARRIAGE

Heavy-duty frame, all-welded stress-relieve structure. Top grade materials used for toughness. Specially heat-treated connecting pins. 9.0-20-14PR double tires with tire spacer. Front axle oscillating hydraulically. Rear dozer as a standard or outrigger as an option. Dozer and outrigger can be installed in front and rear interchangeably. 18-19.5 20 PR tubeless single and 10.0-20 16 PR double tires as an option.

ENVIRONMENT

Noise levels comply with environmental regulations (dynamic values).

LwA External sound level

101 dB(A) (2000/14/EC)

LPA Operator sound level

74 dB(A) (ISO 6396)

DRIVE

Fully hydrostatic driven, 3 speed power shift transmission, variable displacement, high torque, axial piston motor, foot pedal controls provide smooth travel, hub reduction type front steering axle and rear rigid axle.

Travel speed (fast/slow)

37 km/h (23 mph)

Maximum traction force

7,700 kgf (16,975 lbf)

Maximum grade

35° / 70%

BUCKET

Bucket Type	Capacity		Width		C/W (ton)	1.8			2.5	
	SAE/PCSA	CECE	W/O Cutter	With Cutter	Weight	4.3m Boom	4.6m Boom		4.6m Boom	
						2.1m Arm	2.1m Arm	2.5m Arm	2.1m Arm	2.5m Arm
General Purpose Bucket	0.24m ³	0.22m ³	458 mm	534 mm	272 kg	A	A	A	A	A
	0.39m ³	0.35m ³	736 mm	820 mm	338 kg	A	A	A	A	A
	0.45m ³	0.40m ³	821 mm	911 mm	376 kg	A	A	A	A	A
	0.51m ³	0.45m ³	907 mm	991 mm	389 kg	A	A	B	A	A
	0.59m ³	0.51m ³	997 mm	1081 mm	408 kg	B	B	B	A	B
	0.64m ³	0.55m ³	1083 mm	1167 mm	431 kg	B	B	C	A	B
Heavy Duty Bucket	0.76m ³	0.65m ³	1255 mm	1339 mm	479 kg	C	C	C	B	C
	0.21m ³	0.20m ³	450 mm	N/A	313 kg	A	A	A	A	A
	0.31m ³	0.29m ³	600 mm	N/A	372 kg	A	A	A	A	A
	0.42m ³	0.38m ³	750 mm	N/A	420 kg	A	A	A	A	A
	0.52m ³	0.47m ³	900 mm	N/A	478 kg	A	B	C	A	A
	0.60m ³	0.53m ³	1,000 mm	N/A	510 kg	C	C	D	A	A
	0.67m ³	0.60m ³	1,100 mm	N/A	542 kg	C	D	D	A	A
	0.74m ³	0.66m ³	1,200 mm	N/A	585 kg	D	D	X	A	B

Based on ISO 10567 and SAE J296, arm length without quick change clamp

A : Suitable for materials with density of 2100kg/m³ (3500lb/yd³) or less
B : Suitable for materials with density of 1800kg/m³ (3000lb/yd³) or less
C : Suitable for materials with density of 1500kg/m³ (2500lb/yd³) or less

D : Suitable for materials with density of 1200kg/m³ (2000lb/yd³) or less
X : Not recommended

This bucket recommendation is based on machine stability considering the tipping load with certain density of handling material, and should be strictly followed. It's more recommendable to use a smaller size of bucket than recommendation under the severe working condition and application to avoid the durability risks.

REFILL CAPACITIES

Fuel tank	280 l (74 US gal, 61.6 Imp gal)
Cooling system (Radiator capacity)	20 l (5.3 US gal, 4.4 Imp gal)
Engine oil	22 l (5.8 US gal, 4.8 Imp gal)
Swing drive	2 l (0.5 US gal, 0.4 Imp gal)
Power train(each)	Front Axle 2.5 l (0.66 US gal, 0.55 Imp gal) Rear Axle 2.4 l (0.63 US gal, 0.53 Imp gal) Transmission 2.5 l (0.66 US gal, 0.55 Imp gal)
Hydraulic tank	102 l (26.9 US gal, 22.4 Imp gal)

DIMENSIONS

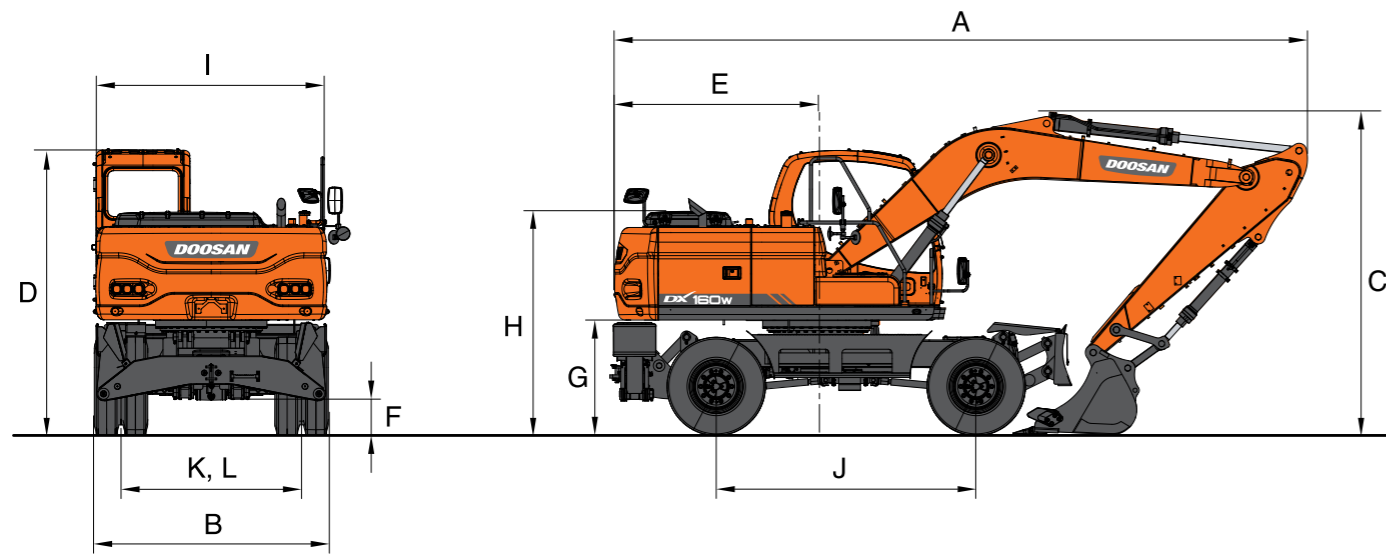

DIMENSIONS

Boom type (One-piece)	4,300mm (14'1")	4,600mm (15'1")	
Arm type	2,100mm (6'11")	2,100mm(6'11") (6'11")	2,500mm (8'2")
A Shipping Length	7,235mm (23'9")	7,820mm (25'8")	7,470mm (24'6")
B Shipping Width	2,496mm (8'2")	←	←
C Shipping Height (Boom)	3,351mm (11')	3,225mm (10'7")	3,460mm (11'4")
D Height Over Cab,	3,040mm (10')	←	←
E Counter Weight Swing Clearance	2,200mm (7'3")	←	←
F Ground Clearance	350mm (1'2")	←	←
G Counter Weight Clearance	1,206mm (4')	←	←
H Engine Cover Height	2,376mm (7'10")	←	←
I Upper Housing Width	2,494mm (8'2")	←	←
J Wheel Base	2,800mm (9'2")	←	←
K,L Tread Width	1,944mm (6'5")	←	←

DIGGING FORCE (ISO)

Bucket (PCSA)	0.24m ³	0.39m ³	0.45m ³	0.51m ³	0.59m ³	0.64m ³	0.76m ³
Digging force	10,140 kgf	10,140 kgf	10,140 kgf	10,140 kgf	10,140 kgf	10,140 kgf	10,140 kgf
	99.5 kN	99.5 kN	99.5 kN	99.5 kN	99.5 kN	99.5 kN	99.5 kN
	22,355 lbf	22,355 lbf	22,355 lbf	22,355 lbf	22,355 lbf	22,355 lbf	22,355 lbf
Arm	2,100mm			2,500mm			
Digging force	7,650 kgf			6,550 kgf			
	75.02 kN			64.23 kN			
	16,865 lbf			14,440 lbf			

At power boost (ISO)

WORKING RANGES

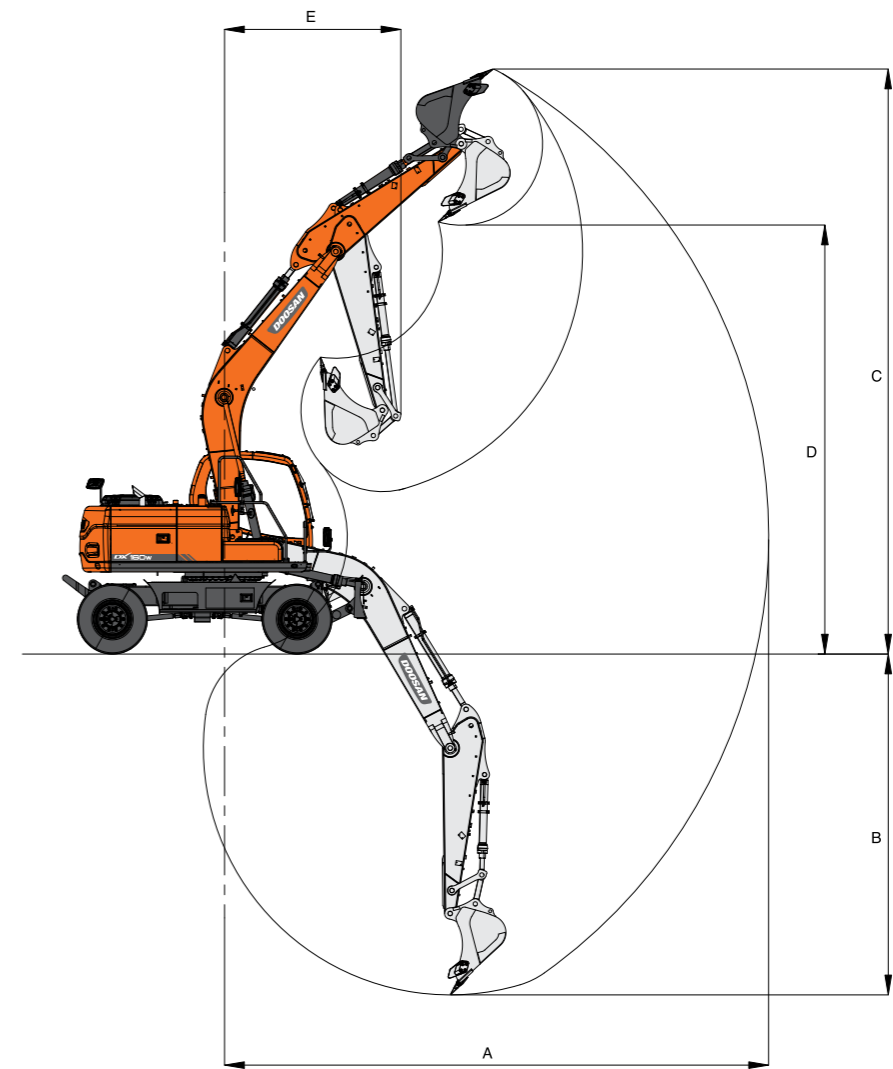

DIMENSIONS

Boom type (One-piece)	4,300mm (14'1")	4,600mm (15'1")	
Arm type	2,100mm (6'11")	2,100mm (6'11")	2,500mm (8'2")
A Max. Digging Reach	7,520mm (24'8")	7,790mm (25'7")	8,250mm (27'1")
B Max. Digging Depth	4,580mm (15')	4,790mm (15'9")	5,190mm (17')
C Max. Digging Height	8,130mm (26'8")	8,370mm (27'6")	8,850mm (29')
D Max. Dump Height	5,810mm (19'1")	6,060mm (19'11")	6,480mm (21'3")
E Min. Swing Radius	2,470mm (8'1")	2,570mm (8'5")	2,670mm (8'9")

LIFTING CAPACITY

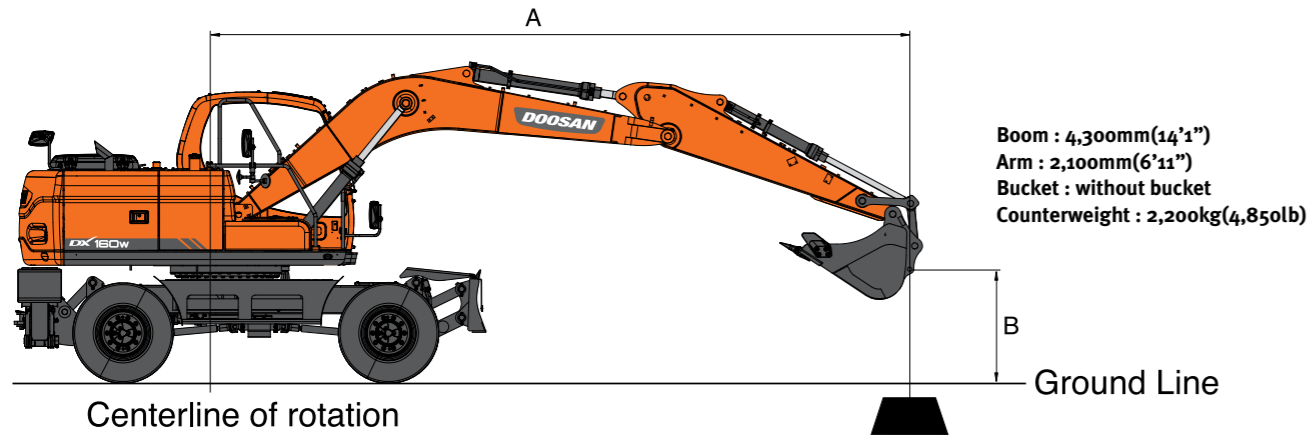

Metric

Unit : 1,000kg

A(m)	B(m)	Chassis Frame Attachment	3		4		5		6		Max. Reach		A(m)
6	6	R-Rear Dozer Only Up			*4.43	4.24					*2.97	*2.97	4.59
		R-Rear Dozer Only Down			*4.43	*4.43					*2.97	*2.97	
		R-Outrigger Only Down			*4.43	*4.43					*2.97	*2.97	
		F-Dozer + R-Outrigger Down			*4.43	*4.43					*2.97	*2.97	
5	5	R-Rear Dozer Only Up			*5.26	4.22	*4.18	3.02			*2.87	2.72	5.36
		R-Rear Dozer Only Down			*5.26	*5.26	*4.18	3.97			*2.87	*2.87	
		R-Outrigger Only Down			*5.26	*5.26	*4.18	*4.18			*2.87	*2.87	
		F-Dozer + R-Outrigger Down			*5.26	*5.26	*4.18	*4.18			*2.87	*2.87	
4	4	R-Rear Dozer Only Up	*7.12	6.42	*6.10	4.15	*5.51	2.99			*2.87	2.37	5.86
		R-Rear Dozer Only Down	*7.12	*7.12	*6.10	5.55	*5.51	3.94			*2.87	*2.87	
		R-Outrigger Only Down	*7.12	*7.12	*6.10	*6.10	*5.51	*5.51			*2.87	*2.87	
		F-Dozer + R-Outrigger Down	*7.12	*7.12	*6.10	*6.10	*5.51	*5.51			*2.87	*2.87	
3	3	R-Rear Dozer Only Up	*9.01	6.16	*6.96	4.03	5.85	2.94	*3.91	2.27	*2.96	2.19	6.15
		R-Rear Dozer Only Down	*9.01	8.69	*6.96	5.43	5.85	3.88	*3.91	2.97	*2.96	2.86	
		R-Outrigger Only Down	*9.01	*9.01	*6.96	*6.96	*5.92	5.89	*3.91	*3.91	*2.96	*2.96	
		F-Dozer + R-Outrigger Down	*9.01	*9.01	*6.96	*6.96	*5.92	*5.92	*3.91	*3.91	*2.96	*2.96	
2	2	R-Rear Dozer Only Up			*7.82	3.92	5.78	2.88	4.36	2.24	*3.13	2.11	6.28
		R-Rear Dozer Only Down			*7.82	5.30	5.78	3.82	4.36	2.95	*3.13	2.76	
		R-Outrigger Only Down			*7.82	*7.82	6.06	5.82	4.57	4.39	*3.13	*3.13	
		F-Dozer + R-Outrigger Down			*7.82	*7.82	*6.35	6.04	*4.97	4.56	*3.13	*3.13	
1	1	R-Rear Dozer Only Up	*9.08	5.76	8.28	3.82	5.71	2.83	4.33	2.22	*3.40	2.11	6.24
		R-Rear Dozer Only Down	*9.08	8.21	8.28	5.20	5.71	3.76	4.33	2.92	*3.40	2.77	
		R-Outrigger Only Down	*9.08	*9.08	*8.37	8.34	6.00	5.76	4.54	4.36	*3.40	*3.40	
		F-Dozer + R-Outrigger Down	*9.08	*9.08	*8.37	*8.37	*6.64	5.98	*5.36	4.53	*3.40	*3.40	
0 (Ground)	0 (Ground)	R-Rear Dozer Only Up	*10.23	5.71	8.21	3.77	5.67	2.80	*4.13	2.20	*3.84	2.19	6.03
		R-Rear Dozer Only Down	*10.23	8.16	8.21	5.14	5.67	3.73	*4.13	2.90	*3.84	2.89	
		R-Outrigger Only Down	*10.23	*10.23	*8.44	8.27	5.96	5.72	*4.13	*4.13	*3.84	*3.84	
		F-Dozer + R-Outrigger Down	*10.23	*10.23	*8.44	*8.44	*6.66	5.94	*4.13	*4.13	*3.84	*3.84	
-1	-1	R-Rear Dozer Only Up	*10.36	5.71	*8.00	3.76	5.66	2.79			*4.57	2.39	5.63
		R-Rear Dozer Only Down	*10.36	8.16	*8.00	5.13	5.66	3.72			*4.57	3.17	
		R-Outrigger Only Down	*10.36	*10.36	*8.00	*8.00	5.95	5.71			*4.57	*4.57	
		F-Dozer + R-Outrigger Down	*10.36	*10.36	*8.00	*8.00	*6.28	5.93			*4.57	*4.57	
-2	-2	R-Rear Dozer Only Up	*8.87	5.76	*6.93	3.79	*5.12	2.82			*5.11	2.81	5.01
		R-Rear Dozer Only Down	*8.87	8.21	*6.93	5.16	*5.12	3.75			*5.11	3.75	
		R-Outrigger Only Down	*8.87	*8.87	*6.93	*6.93	*5.12	*5.12			*5.11	*5.11	
		F-Dozer + R-Outrigger Down	*8.87	*8.87	*6.93	*6.93	*5.12	*5.12			*5.11	*5.11	
-3	-3	R-Rear Dozer Only Up	*6.38	5.85	*4.63	3.87					*4.54	3.82	4.04
		R-Rear Dozer Only Down	*6.38	*6.38	*4.63	*4.63					*4.54	*4.54	
		R-Outrigger Only Down	*6.38	*6.38	*4.63	*4.63					*4.54	*4.54	
		F-Dozer + R-Outrigger Down	*6.38	*6.38	*4.63	*4.63					*4.54	*4.54	

Feet

Unit : 1,000lb

A(ft)	B(ft)	Chassis Frame Attachment	3		4		5		Max. Reach		A(ft)		
20	20	R-Rear Dozer Only Up										18.37	
		R-Rear Dozer Only Down											
		R-Outrigger Only Down											
		F-Dozer + R-Outrigger Down											
15	15	R-Rear Dozer Only Up							*11.76	7.59		*6.30	5.60
		R-Rear Dozer Only Down							*11.76	10.02		*6.30	*6.30
		R-Outrigger Only Down							*11.76	*11.76		*6.30	*6.30
		F-Dozer + R-Outrigger Down							*11.76	*11.76		*6.30	*6.30
10	10	R-Rear Dozer Only Up	*19.35	13.29	*13.81	7.36	*7.25	4.89			*6.51	4.83	20.16
		R-Rear Dozer Only Down	*19.35	18.66	*13.81	9.78	*7.25	6.41			*6.51	6.33	
		R-Outrigger Only Down	*19.35	*19.35	*13.81	*13.81	*7.25	*7.25			*6.51	*6.51	
		F-Dozer + R-Outrigger Down	*19.35	*19.35	*13.81	*13.81	*7.25	*7.25			*6.51	*6.51	
5	5	R-Rear Dozer Only Up	*24.32	12.53	14.63	7.10	9.35	4.81	*7.15	4.62			20.59
		R-Rear Dozer Only Down	*24.32	17.78	14.63	9.50	9.35	6.32	*7.15	6.07			
		R-Outrigger Only Down	*24.32	*24.32	15.35	14.74	9.81	9.42	*7.15	*7.15			
		F-Dozer + R-Outrigger Down	*24.32	*24.32	*15.65	15.30	*10.24	9.79	*7.15	*7.15			
0 (Ground)	0 (Ground)	R-Rear Dozer Only Up	*23.70	12.28	14.43	6.94					*8.46	4.83	19.77
		R-Rear Dozer Only Down	*23.70	17.49	14.43	9.33					*8.46	6.37	
		R-Outrigger Only Down	*23.70	*23.70	15.15	14.54					*8.46	*8.46	
		F-Dozer + R-Outrigger Down	*23.70	*23.70	*16.17	15.10					*8.46	*8.46	
-5	-5	R-Rear Dozer Only Up	*21.06	12.33	*14.39	6.94					11.34	5.68	17.51
		R-Rear Dozer Only Down	*21.06	17.55	*14.39	9.32					11.34	7.53	
		R-Outrigger Only Down	*21.06	*21.06	*14.39	*14.39					*11.44	11.42	
		F-Dozer + R-Outrigger Down	*21.06	*21.06	*14.39	*14.39					*11.44	*11.44	
-10	-10	R-Rear Dozer Only Up	*13.55	12.60							*9.89	8.60	13.06
		R-Rear Dozer Only Down	*13.55	*13.55							*9.89	*9.89	
		R-Outrigger Only Down	*13.55	*13.55							*9.89	*9.89	
		F-Dozer + R-Outrigger Down	*13.55	*13.55							*9.89	*9.89	

1. Ratings are based on SAE J1097
2. Load point is the end of arm.
3. * Rated loads are based on hydraulic capacity.
4. Rated loads do not exceed 87% of hydraulic capacity or 75% of tipping capacity.

: Rating Over Front
 : Rating Over Side or 360 degree

LIFTING CAPACITY

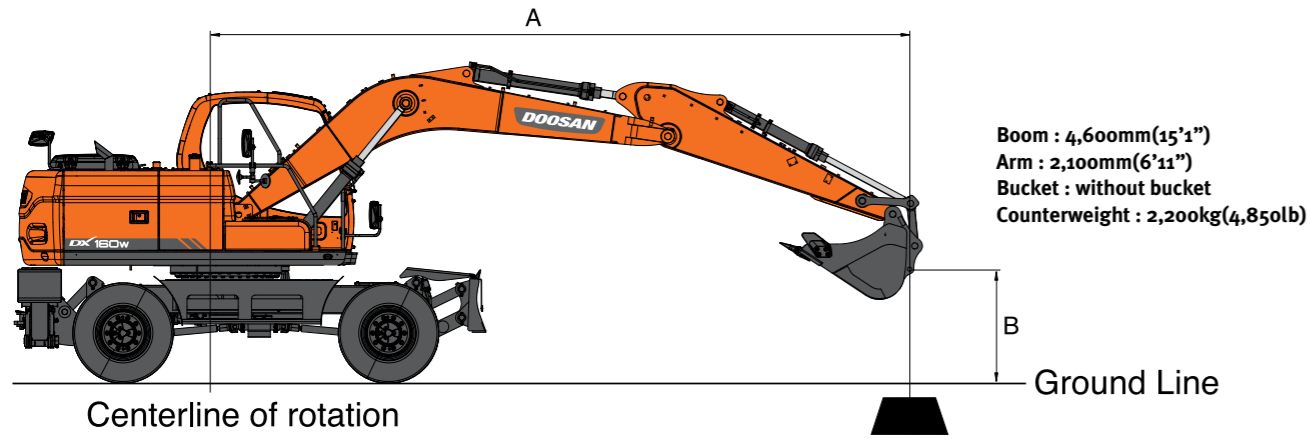

Metric

Unit : 1,000kg

A(m)	B(m)	Chassis Frame Attachment	3		4		5		6		Max. Reach		A(m)
6	6	R-Rear Dozer Only Up			*4.86	4.25	*3.10	3.01			*2.98	*2.98	5.02
		R-Rear Dozer Only Down			*4.86	*4.86	*3.10	*3.10			*2.98	*2.98	
		R-Outrigger Only Down			*4.86	*4.86	*3.10	*3.10			*2.98	*2.98	
		F-Dozer + R-Outrigger Down			*4.86	*4.86	*3.10	*3.10			*2.98	*2.98	
5	5	R-Rear Dozer Only Up			*5.48	4.21	*4.93	3.02			*2.90	2.45	5.74
		R-Rear Dozer Only Down			*5.48	*5.48	*4.93	3.97			*2.90	*2.90	
		R-Outrigger Only Down			*5.48	*5.48	*4.93	*4.93			*2.90	*2.90	
		F-Dozer + R-Outrigger Down			*5.48	*5.48	*4.93	*4.93			*2.90	*2.90	
4	4	R-Rear Dozer Only Up	*7.45	6.36	*6.14	4.11	*5.42	2.97	*3.97	2.28	*2.90	2.16	6.20
		R-Rear Dozer Only Down	*7.45	*7.45	*6.14	5.52	*5.42	3.92	*3.97	2.98	*2.90	2.83	
		R-Outrigger Only Down	*7.45	*7.45	*6.14	*6.14	*5.42	*5.42	*3.97	*3.97	*2.90	*2.90	
		F-Dozer + R-Outrigger Down	*7.45	*7.45	*6.14	*6.14	*5.42	*5.42	*3.97	*3.97	*2.90	*2.90	
3	3	R-Rear Dozer Only Up			*7.03	3.98	5.82	2.91	4.37	2.25	*2.99	2.01	6.49
		R-Rear Dozer Only Down			*7.03	5.37	5.82	3.85	4.37	2.95	*2.99	2.64	
		R-Outrigger Only Down				*7.03	*7.03	*5.86	*5.86	4.59	4.41	*2.99	
		F-Dozer + R-Outrigger Down			*7.03	*7.03	*5.86	*5.86	*5.18	4.58	*2.99	*2.99	
2	2	R-Rear Dozer Only Up			*7.86	3.85	5.74	2.84	4.33	2.21	*3.14	1.94	6.60
		R-Rear Dozer Only Down			*7.86	5.23	5.74	3.78	4.33	2.92	*3.14	2.55	
		R-Outrigger Only Down			*7.86	*7.86	6.02	5.78	4.55	4.37	*3.14	*3.14	
		F-Dozer + R-Outrigger Down			*7.86	*7.86	*6.30	6.00	*5.37	4.54	*3.14	*3.14	
1	1	R-Rear Dozer Only Up			8.20	3.75	5.67	2.78	4.29	2.18	*3.39	1.93	6.56
		R-Rear Dozer Only Down			8.20	5.12	5.67	3.71	4.29	2.88	*3.39	2.55	
		R-Outrigger Only Down			*8.33	8.26	5.95	5.71	4.51	4.33	*3.39	*3.39	
		F-Dozer + R-Outrigger Down			*8.33	*8.33	*6.58	5.93	*5.47	4.50	*3.39	*3.39	
0 (Ground)	0 (Ground)	R-Rear Dozer Only Up	*7.26	5.60	8.14	3.70	5.62	2.74	4.27	2.16	*3.77	2.00	6.36
		R-Rear Dozer Only Down	*7.26	*7.26	8.14	5.07	5.62	3.68	4.27	2.86	*3.77	2.65	
		R-Outrigger Only Down	*7.26	*7.26	*8.34	8.19	5.67	5.67	4.49	*4.31	*3.77	*3.77	
		F-Dozer + R-Outrigger Down	*7.26	*7.26	*8.34	*8.34	*6.61	5.89	*5.38	4.48	*3.77	*3.77	
-1	-1	R-Rear Dozer Only Up	*10.06	5.61	*7.90	3.69	5.61	2.73			4.28	2.17	5.99
		R-Rear Dozer Only Down	*10.06	8.06	*7.90	5.06	5.61	3.66			4.28	2.87	
		R-Outrigger Only Down	*10.06	*10.06	*7.90	*7.90	5.89	5.65			*4.40	4.32	
		F-Dozer + R-Outrigger Down	*10.06	*10.06	*7.90	*7.90	*6.28	5.88			*4.40	*4.40	
-2	-2	R-Rear Dozer Only Up	*8.71	5.66	*6.96	3.72	*5.43	2.75			*4.74	2.50	5.41
		R-Rear Dozer Only Down	*8.71	8.11	*6.96	5.08	*5.43	3.69			*4.74	3.32	
		R-Outrigger Only Down	*8.71	*8.71	*6.96	*6.96	*5.43	*5.43			*4.74	*4.74	
		F-Dozer + R-Outrigger Down	*8.71	*8.71	*6.96	*6.96	*5.43	*5.43			*4.74	*4.74	
-3	-3	R-Rear Dozer Only Up	*6.62	5.75	*5.21	3.78					*4.28	3.20	4.53
		R-Rear Dozer Only Down	*6.62	*6.62	*5.21	5.15					*4.28	*4.28	
		R-Outrigger Only Down	*6.62	*6.62	*5.21	*5.21					*4.28	*4.28	
		F-Dozer + R-Outrigger Down	*6.62	*6.62	*5.21	*5.21					*4.28	*4.28	

Feet

Unit : 1,000lb

A(ft)	B(ft)	Chassis Frame Attachment	3		4		5		Max. Reach		A(ft)
20	20	R-Rear Dozer Only Up			*9.14	7.64			*6.61	*6.61	16.2
		R-Rear Dozer Only Down			*9.14	*9.14			*6.61	*6.61	
		R-Outrigger Only Down			*9.14	*9.14			*6.61	*6.61	
		F-Dozer + R-Outrigger Down			*9.14	*9.14			*6.61	*6.61	
15	15	R-Rear Dozer Only Up			*11.93	7.55			*6.37	5.08	19.56
		R-Rear Dozer Only Down			*11.93	10			*6.37	*6.37	
		R-Outrigger Only Down			*11.93	*11.93			*6.37	*6.37	
		F-Dozer + R-Outrigger Down			*11.93	*11.93			*6.37	*6.37	
10	10	R-Rear Dozer Only Up			*13.78	7.28	9.41	4.85	*6.57	4.44	21.25
		R-Rear Dozer Only Down			*13.78	9.7	9.41	6.37	*6.57	5.82	
		R-Outrigger Only Down			*13.78	*13.78	9.88	9.49	*6.57	*6.57	
		F-Dozer + R-Outrigger Down			*13.78	*13.78	*10.95	9.86	*6.57	*6.57	
5	5	R-Rear Dozer Only Up			14.51	6.98	9.29	4.74	*7.16	4.25	21.66
		R-Rear Dozer Only Down			14.51	9.38	9.29	6.25	*7.16	5.59	
		R-Outrigger Only Down			15.23	14.62	9.75	9.36	*7.16	*7.16	
		F-Dozer + R-Outrigger Down			*15.58	15.18	*11.81	9.73	*7.16	*7.16	
0 (Ground)	0 (Ground)	R-Rear Dozer Only Up	*16.79	12.05	14.30	6.81	9.20	4.67	*8.32	4.42	20.88
		R-Rear Dozer Only Down	*16.79	*16.79	14.30	9.19	9.20	6.18	*8.32	5.84	
		R-Outrigger Only Down	*16.79	*16.79	15.01	14.41	9.67	9.28	*8.32	*8.32	
		F-Dozer + R-Outrigger Down	*16.79	*16.79	*16.01	14.97	*11.62	9.65	*8.32	*8.32	
-5	-5	R-Rear Dozer Only Up	*20.54	12.12	14.28	6.80			10.14	5.10	18.75
		R-Rear Dozer Only Down	*20.54	17.32	14.28	9.18			10.14	6.76	
		R-Outrigger Only Down	*20.54	*20.54	*14.45	14.39			10.65	10.22	
		F-Dozer + R-Outrigger Down	*20.54	*20.54	*14.45	*14.45			*10.66	10.62	
-10	-10	R-Rear Dozer Only Up	*14.17	12.38					*9.34	7.18	14.69
		R-Rear Dozer Only Down	*14.17	*14.17					*9.34	*9.34	
		R-Outrigger Only Down	*14.17	*14.17					*9.34	*9.34	
		F-Dozer + R-Outrigger Down	*14.17	*14.17					*9.34	*9.34	

1. Ratings are based on SAE J1097
2. Load point is the end of arm.
3. * Rated loads are based on hydraulic capacity.
4. Rated loads do not exceed 87% of hydraulic capacity or 75% of tipping capacity.

: Rating Over Front
 : Rating Over Side or 360 degree

LIFTING CAPACITY

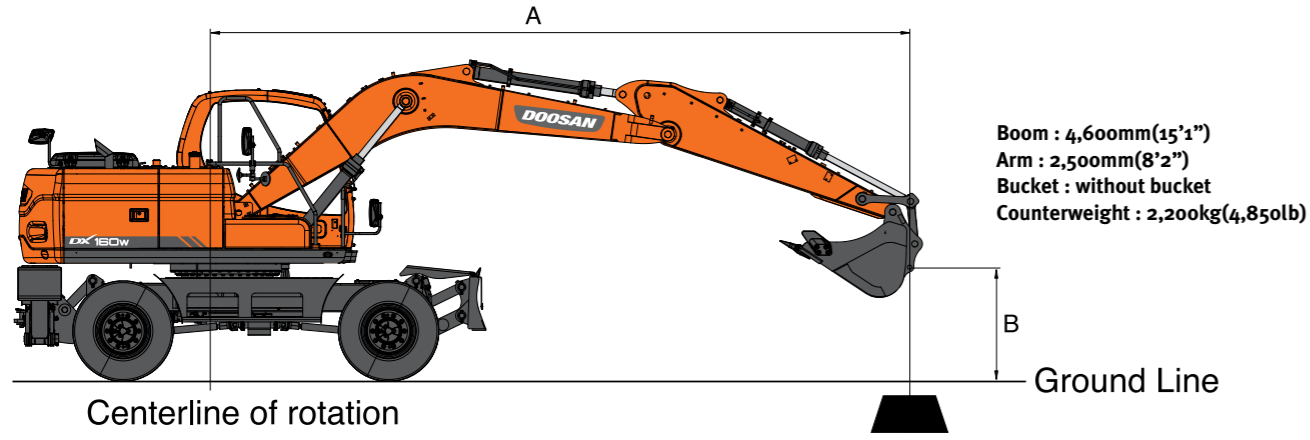

Metric Unit : 1,000kg

A(m)	B(m)	3		4		5		6		Max. Reach		A(m)
6	R-Rear Dozer Only Up					*3.56	3.05			*2.10	*2.10	5.62
	R-Rear Dozer Only Down					*3.56	*3.56			*2.10	*2.10	
	R-Outrigger Only Down					*3.56	*3.56			*2.10	*2.10	
	F-Dozer + R-Outrigger Down					*3.56	*3.56			*2.10	*2.10	
5	R-Rear Dozer Only Up			*4.27	4.25	*4.19	3.04	*3.02	2.30	*2.02	*2.02	6.26
	R-Rear Dozer Only Down			*4.27	*4.27	*4.19	4	*3.02	3.01	*2.02	*2.02	
	R-Outrigger Only Down			*4.27	*4.27	*4.19	*4.19	*3.02	*3.02	*2.02	*2.02	
	F-Dozer + R-Outrigger Down			*4.27	*4.27	*4.19	*4.19	*3.02	*3.02	*2.02	*2.02	
4	R-Rear Dozer Only Up			*5.25	4.15	*4.93	2.99	*4.05	2.28	*2.01	1.93	6.69
	R-Rear Dozer Only Down			*5.25	*5.25	*4.93	3.94	*4.05	3	*2.01	*2.01	
	R-Outrigger Only Down			*5.25	*5.25	*4.93	*4.93	*4.05	*4.05	*2.01	*2.01	
	F-Dozer + R-Outrigger Down			*5.25	*5.25	*4.93	*4.93	*4.05	*4.05	*2.01	*2.01	
3	R-Rear Dozer Only Up	*8.55	6.14	*6.59	4.01	*5.57	2.92	4.38	2.25	*2.04	1.81	6.95
	R-Rear Dozer Only Down	*8.55	*8.55	*6.59	5.41	*5.57	3.86	4.38	2.96	*2.04	*2.04	
	R-Outrigger Only Down	*8.55	*8.55	*6.59	*6.59	*5.57	*5.57	4.60	4.41	*2.04	*2.04	
	F-Dozer + R-Outrigger Down	*8.55	*8.55	*6.59	*6.59	*5.57	*5.57	*4.92	4.58	*2.04	*2.04	
2	R-Rear Dozer Only Up			*7.52	3.86	5.74	2.84	4.33	2.20	*2.11	1.75	7.06
	R-Rear Dozer Only Down			*7.52	5.25	5.74	3.78	4.33	2.91	*2.11	*2.11	
	R-Outrigger Only Down			*7.52	*7.52	6.03	5.79	4.54	4.36	*2.11	*2.11	
	F-Dozer + R-Outrigger Down			*7.52	*7.52	*6.08	6.01	*5.22	4.53	*2.11	*2.11	
1	R-Rear Dozer Only Up			*8.15	3.75	5.66	2.77	4.28	2.16	*2.23	1.75	7.02
	R-Rear Dozer Only Down			*8.15	5.12	5.66	3.70	4.28	2.87	*2.23	*2.23	
	R-Outrigger Only Down			*8.15	*8.15	5.94	5.70	4.50	4.32	*2.23	*2.23	
	F-Dozer + R-Outrigger Down			*8.15	*8.15	*6.45	5.93	*5.40	4.49	*2.23	*2.23	
0 (Ground)	R-Rear Dozer Only Up	*6.95	5.56	8.11	3.68	5.60	2.72	4.25	2.14	*2.42	1.80	6.84
	R-Rear Dozer Only Down	*6.95	*6.95	8.11	5.04	5.60	3.65	4.25	2.84	*2.42	2.38	
	R-Outrigger Only Down	*6.95	*6.95	*8.35	8.17	5.88	5.65	4.47	4.28	*2.42	*2.42	
	F-Dozer + R-Outrigger Down	*6.95	*6.95	*8.35	*8.35	*6.60	5.87	*5.42	4.45	*2.42	*2.42	
-1	R-Rear Dozer Only Up	*9.04	5.55	8.08	3.65	5.58	2.70	4.24	2.13	*2.71	1.93	6.50
	R-Rear Dozer Only Down	*9.04	7.99	8.08	5.02	5.58	3.63	4.24	2.83	*2.71	2.55	
	R-Outrigger Only Down	*9.04	*9.04	*8.09	*8.09	5.86	5.62	4.46	4.27	*2.71	*2.71	
	F-Dozer + R-Outrigger Down	*9.04	*9.04	*8.09	*8.09	*6.42	5.84	*5.17	4.44	*2.71	*2.71	
-2	R-Rear Dozer Only Up	*9.41	5.58	*7.37	3.66	5.59	2.71			*3.19	2.17	5.96
	R-Rear Dozer Only Down	*9.41	8.03	*7.37	5.03	5.59	3.64			*3.19	2.88	
	R-Outrigger Only Down	*9.41	*9.41	*7.37	*7.37	*5.83	5.63			*3.19	*3.19	
	F-Dozer + R-Outrigger Down	*9.41	*9.41	*7.37	*7.37	*5.83	*5.83			*3.19	*3.19	
-3	R-Rear Dozer Only Up	*7.62	5.66	*6.01	3.71	*4.43	2.76			*4.03	2.64	5.18
	R-Rear Dozer Only Down	*7.62	*7.62	*6.01	5.08	*4.43	3.69			*4.03	3.52	
	R-Outrigger Only Down	*7.62	*7.62	*6.01	*6.01	*4.43	*4.43			*4.03	*4.03	
	F-Dozer + R-Outrigger Down	*7.62	*7.62	*6.01	*6.01	*4.43	*4.43			*4.03	*4.03	

Feet Unit : 1,000lb

A(ft)	B(ft)	3		4		5		Max. Reach		A(ft)		
20	R-Rear Dozer Only Up					*8.43	7.72			*4.65	*4.65	18.18
	R-Rear Dozer Only Down					*8.43	*8.43			*4.65	*4.65	
	R-Outrigger Only Down					*8.43	*8.43			*4.65	*4.65	
	F-Dozer + R-Outrigger Down					*8.43	*8.43			*4.65	*4.65	
15	R-Rear Dozer Only Up					*10.04	7.61	*7.36	4.94	*4.44	*4.44	21.22
	R-Rear Dozer Only Down					*10.04	*10.04	*7.36	6.47	*4.44	*4.44	
	R-Outrigger Only Down					*10.04	*10.04	*7.36	*7.36	*4.44	*4.44	
	F-Dozer + R-Outrigger Down					*10.04	*10.04	*7.36	*7.36	*4.44	*4.44	
10	R-Rear Dozer Only Up	*18.35	13.25	*13.03	7.31	9.42	4.85	*4.50	3.99			22.78
	R-Rear Dozer Only Down	*18.35	*18.35	*13.03	9.74	9.42	6.37	*4.50	*4.50			
	R-Outrigger Only Down	*18.35	*18.35	*13.03	*13.03	9.89	9.5	*4.50	*4.50			
	F-Dozer + R-Outrigger Down	*18.35	*18.35	*13.03	*13.03	*10.39	9.87	*4.50	*4.50			
5	R-Rear Dozer Only Up					14.53	6.98	9.27	4.71	*4.77	3.84	23.17
	R-Rear Dozer Only Down					14.53	9.38	9.27	6.23	*4.77	*4.77	
	R-Outrigger Only Down					*15.10	14.63	9.73	9.34	*4.77	*4.77	
	F-Dozer + R-Outrigger Down					*15.10	*15.10	*11.56	9.71	*4.77	*4.77	
0 (Ground)	R-Rear Dozer Only Up	*16.06	11.96	14.25	6.76	9.15	4.61	*5.34	3.97			22.44
	R-Rear Dozer Only Down	*16.06	*16.06	14.25	9.14	9.15	6.13	*5.34	5.25			
	R-Outrigger Only Down	*16.06	*16.06	14.97	14.36	9.62	9.23	*5.34	*5.34			
	F-Dozer + R-Outrigger Down	*16.06	*16.06	*15.98	14.93	*11.74	9.60	*5.34	*5.34			
-5	R-Rear Dozer Only Up	*21.81	11.96	14.19	6.71	9.15	4.61	*6.46	4.48			20.48
	R-Rear Dozer Only Down	*21.81	17.16	14.19	9.09	9.15	6.12	*6.46	5.94			
	R-Outrigger Only Down	*21.81	*21.81	14.90	14.29	9.62	9.22	*6.46	*6.46			
	F-Dozer + R-Outrigger Down	*21.81	*21.81	*15.00	14.86	*9.81	9.59	*6.46	*6.46			
-10	R-Rear Dozer Only Up	*16.38	12.18	*11.15	6.83			*8.84	5.89			16.85
	R-Rear Dozer Only Down	*16.38	*16.38	*11.15	9.22			*8.84	7.87			
	R-Outrigger Only Down	*16.38	*16.38	*11.15	*11.15			*8.84	*8.84			
	F-Dozer + R-Outrigger Down	*16.38	*16.38	*11.15	*11.15			*8.84	*8.84			

1. Ratings are based on SAE J1097
2. Load point is the end of arm.
3. * Rated loads are based on hydraulic capacity.
4. Rated loads do not exceed 87% of hydraulic capacity or 75% of tipping capacity.

: Rating Over Front
 : Rating Over Side or 360 degree

UNDERCARRIAGE

Undercarriage with front cradle and rear outrigger / front cradle and rear dozer

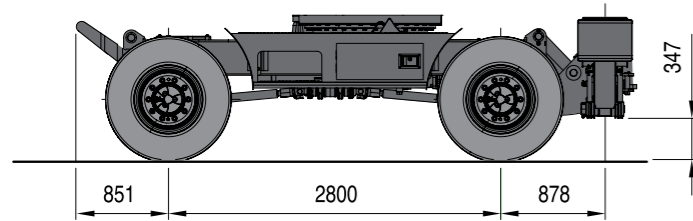

▲ Front Cradle and Rear outrigger

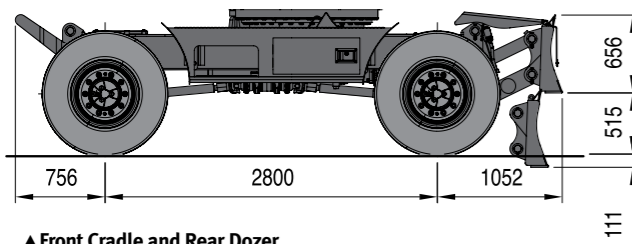

▲ Front Cradle and Rear Dozer

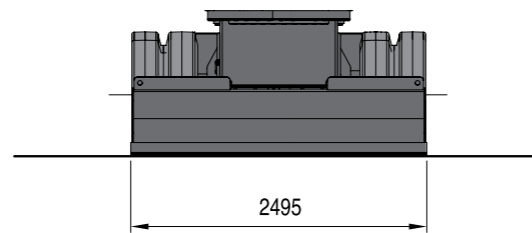

Undercarriage with front outrigger and rear dozer

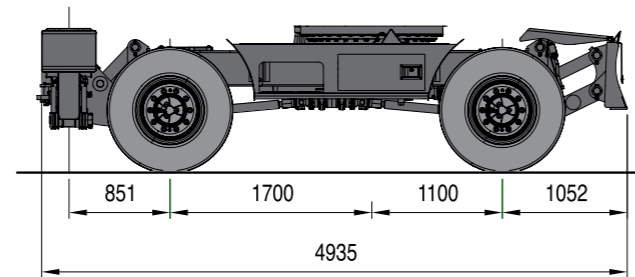
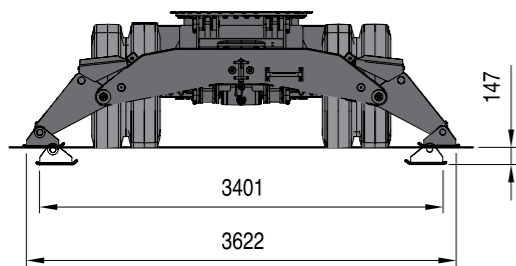

Undercarriage with front outrigger and rear outrigger / front dozer and rear outrigger

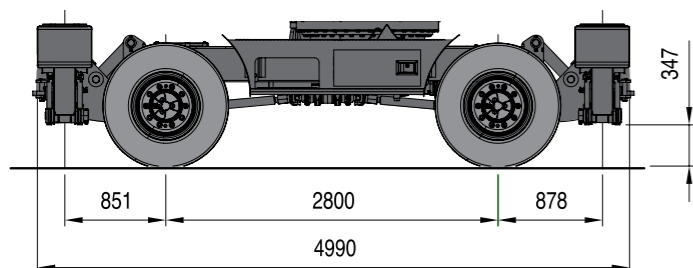

▲ Front Outrigger and Rear Outrigger

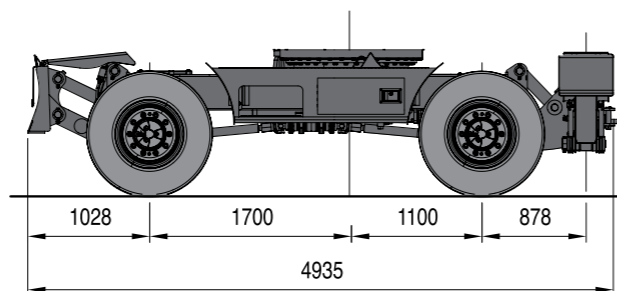

▲ Front Dozer and Rear Outrigger

STANDARD AND OPTIONAL EQUIPMENT

STANDARD EQUIPMENT

Boom & Arm

- 4.6m Boom
- 2.5m Arm

Hydraulic system

- Boom and arm flow regeneration
- Boom and arm holding valves
- Swing anti-rebound valves
- Spare ports(valve)
- One-touch power boost

Cabin & Interior

- Viscous cab mounts
- All weather sound suppressed type cab
- Air conditioner
- Adjustable suspension seat with head rest and adjustable arm rest
- Pull-up type front window and removable lower front window
- Room light
- Intermittent windshield wiper
- Cigarette lighter and ashtray
- Cup holder
- Hot & Cool box
- LCD color monitor panel
- Engine speed (RPM) control dial
- AM/FM radio and cassette player
- Remote radio ON/OFF switch
- 12V spare powers socket
- Serial communication port for laptop PC interface
- Joystick lever with 3 switches
- Sunvisor
- Sun roof
- Wiper

Safety

- Large handrails and step
- Punched metal anti-slip plates
- Seat belt
- Hydraulic safety lock lever
- Safety glass
- Hammer for emergency escape
- Right and left rearview mirrors
- Reverse travel alarm
- Emergency engine stop
- LED stop lamps

Others

- Double element air cleaner
- Dust screen for radiator/oil cooler/Charged Air Cooler
- Engine overheat prevention system
- Engine restart prevention system
- Self-diagnostic system
- Alternator(24V, 60 amps)
- Electric horn
- Halogen working lights(frame mounted 2, boom mounted 2)
- Double fuel filter
- 2.5ton Cast Counterweight

Undercarriage

- 9.00-20 14PR double tires
- Heavy duty axles
- Parallel dozer blade
- Tool box
- 4 Speed(creep, low, econo, high)
- Front axle oscillation cyl. auto Lock

OPTIONAL EQUIPMENT

Some of these optional equipment may be standard in some markets. Some of these optional equipment cannot be available on some markets. You must check with the local DOOSAN dealer to know about the availability or to release the adaptation following the needs of the applications.

Boom & Arm

- 4.3m Boom
- 2.1m Arm

Safety

- Boom and arm hose rupture protection valve
- Overload warning device
- Cabin Top/Front guard(ISO 10262, FOGS standard)
- Rotation beacon
- Mirror & Lamp on counterweight

Cabin & Interior

- Air suspension seat
- 2 Front lamps
- 4 front + 2 rear lamps
- Rain shield

Others

- Piping for crusher
- Piping for quick clamp
- Piping for front attachment rotation
- Lower wiper
- Fuel heater
- Large capacity alternator (24v, 80 amps)
- Fuel filler pump

Undercarriage

- Front Cradle
- Dozer blade
- Outriggers
- Individually controlled outriggers
- 10.00-20 16 PR double tires
- 18-19.5 20 PR single tire
- 10.00-20 14 PR double tires
- 2.2 ton cast counterweight
- 1.8 ton cast counterweight

Doosan is

Since 1896, Doosan, the oldest company in Korea, has evolved with its people. The company grew up rapidly for last 10 years with reputation. For human-oriented vision, Doosan has been building constructions, energy, machines, infra structures globally. As a global leader of infra structure, Doosan continues its vision to make human-oriented future.

First in Korea, Doosan self-developed excavators in 1985 and continued building versatile construction machines including excavators, wheel loaders, articulated dump trucks to execute its human-oriented philosophy. Doosan became a global leader of heavy construction machine industry by achieving global sales line, producing line, and distribution line. Along with large production bases in Korea, China, USA, Belgium, Czech, Brazil, Doosan has 1400 dealer networks and Doosan is providing reliable products and trusted solutions for your stable business at no risk.

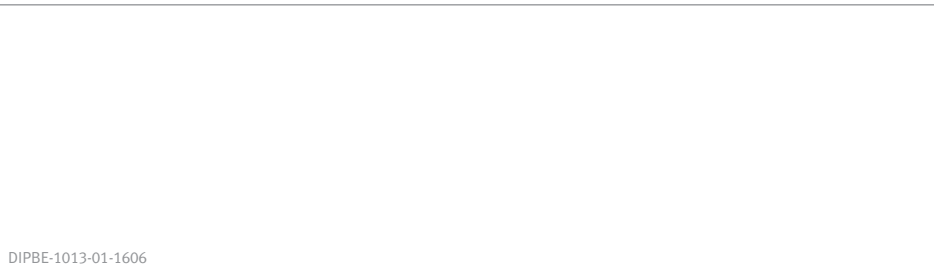

DIPBE-1013-01-1606



Doosan Infracore Korea Office (HQ)
27F, Doosan Tower, 275, Jangchungdan-ro,
Jung-gu, Seoul, Korea(04563)
Tel : 82 2 3398 8114

www.doosaninfracore.com/ce/