

**DOOSAN**



# DVF 5000

Compact, Simultaneous  
5-Axis Machine for  
High-Speed Multitasking



**MACHINE  
GREATNESS™**

**Basic information**

Basic Structure  
Cutting  
Performance

**Detailed Information**

Options  
CUFOS  
Applications  
Diagrams  
Specifications

**Customer Support Service**



# DVF 5000

The new Doosan DVF 5000 5 axis machining center provides world class productivity and reliability for simultaneous 5 axis machining operations. It's stable structure and compact footprint is ideal for production of small to medium size workpieces with complex shapes. The DVF5000 also includes an eco-friendly all-grease lubrication system.

## Contents

### 02 Product Overview

#### Basic Information

04 Basic Structure

07 Cutting Performance

#### Detailed Information

08 Standard / Optional Specifications

10 CUFOS

15 Applications

18 Diagrams

21 Machine / CNC Specifications

26 Customer Support Service



### High productivity & speed Simultaneous 5-Axis Machine

- 12000 / 18000 r/min high speed spindle
- Ø500 mm (19.7 inch) 2-axis tilting table  
(option : Ø630mm (Ø24.8 inch))  
- Max. workpiece weight 400kg (881.8 lb)

### User friendly machine

- Compact footprint
- Grease lubrication system
- Easy operator access to machine
- Compact automation system (AWC)

### High precision function

- Spindle & Structure Thermal Compensation
- Spindle Cooling Standard  
(Option : ballscrew shaft cooling system)

## Product Preview

### Basic information

Basic Structure  
Cutting  
Performance

### Detailed Information

Options  
CUFOS  
Applications  
Diagrams  
Specifications

### Customer Support Service

## Machine configuration

Provides high rigidity and easy operator access.

### Travel distance

**X axis 625 mm**  
(24.6 inch)

**Y axis 450 mm**  
(17.7 inch)

**Z axis 400 mm**  
(15.7 inch)

### Rapid traverse

**X axis 40 m/min**  
(1574.8 ipm)

**Y axis 40 m/min**  
(1574.8 ipm)

**Z axis 40 m/min**  
(1574.8 ipm)

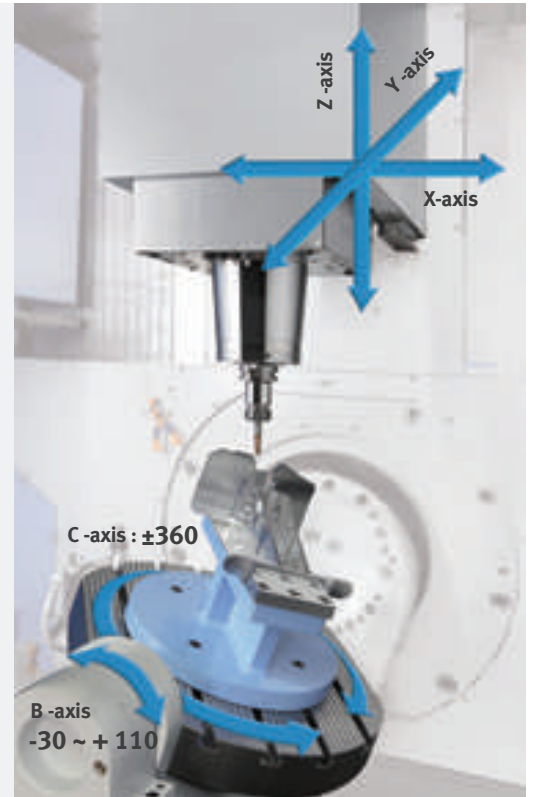

## Spindle

We provide stable machining performance with high speed direct and built-in spindle.

### Max. spindle speed

**12000 r/min /**  
**18000 r/min** option

### Max. spindle motor power & torque

#### Fanuc

**18.5 kW / 118 N·m**  
(24.8 Hp / 87.1 ft-lbs)

**22 kW / 118 N·m** option  
(29.5 Hp / 87.1 ft-lbs)

#### HEIDENHAIN

**17 kW / 109 N·m**  
(22.8 Hp / 80.4 ft-lbs)

**30 kW / 155 N·m** option  
(40.2 Hp / 114.4 ft-lbs)

#### SIEMENS

**16.5 kW / 79 N·m**  
(22.1 Hp / 58.3 ft-lbs)

**30 kW / 155 N·m** option  
(40.2 Hp / 114.4 ft-lbs)

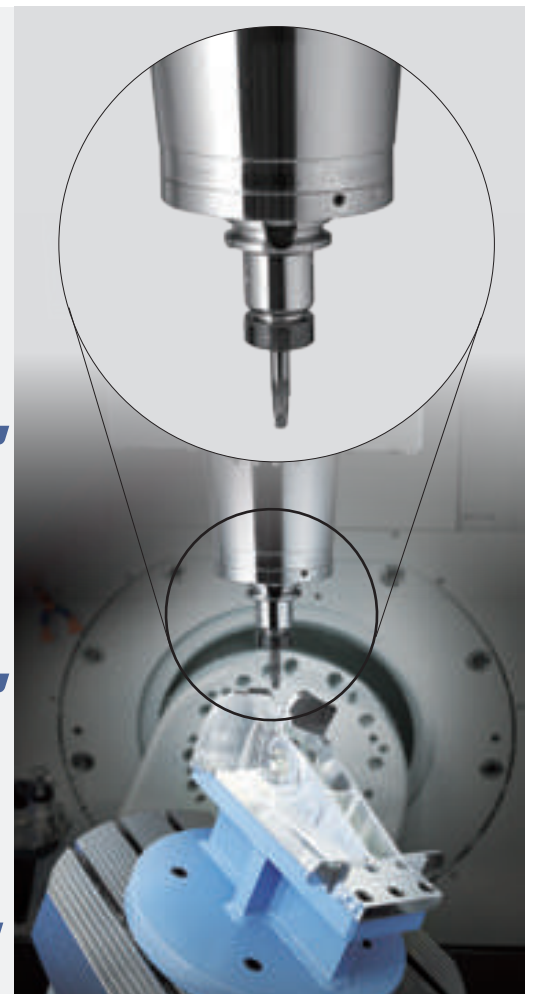



## Tool Magazine

Servo tool magazine as standard for high productivity and reliability.

### Servo Magazine

**30 ea**  
**(40/60/90/120 ea)** option

### Tool to Tool

**1.3 sec**

### ATC Magazine Panel

- More than 60 tools,
  - Touch panel 7 inch (FANUC, SIEMENS)
  - Touch panel 7.5 inch (SIEMENS)
  - Touch panel 10.2 inch (FANUC, HEIDENHAIN) option



120 ea



## Table

Provides stable machining performance with a wide machining area and trunnion support option.

### Table size

**Ø 500 x 450 mm**  
(Ø 19.7 x 17.7 inch)

**Ø 630 x 450 mm** option  
(Ø 24.8 x 17.7 inch)

### Max. workpiece size

**Ø 550 x h 450 mm**  
(Ø 21.7 x 17.7 inch)

### Max. Work load

**400 kg**  
(881.8 lb)

**(with trunnion support)**

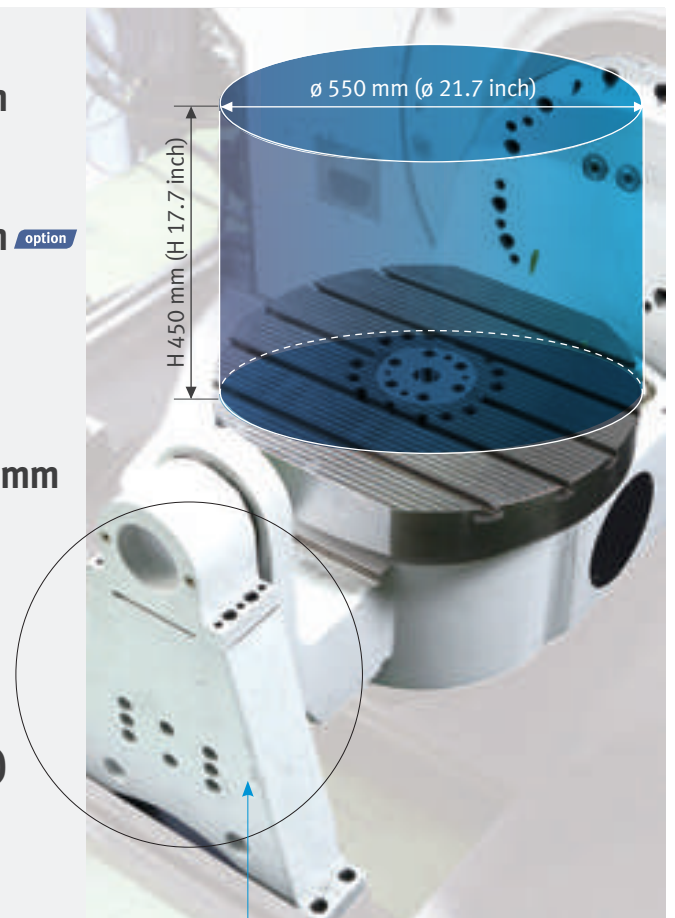

Trunnion support



Basic information



Basic Structure  
Cutting  
Performance

Optimized solution with compact automation.

Detailed Information

Options  
CUFOS  
Applications  
Diagrams  
Specifications

Customer Support Service

Max. workpiece dimensions	Unit	Count	Max. loading	Max. construction height on the pallet
150 x 150 (5.9x5.9) or ø 180 (7.1)	mm (inch)	24	40kg (88.2lb)	350mm (13.8inch)
250 x 250 (9.8x9.8) or ø 300 (11.8)	mm (inch)	12	130kg (286.6lb)	
320 x 320 (12.6x12.6) or ø 360 (14.2)	mm (inch)	10	250kg (551.1lb)	
350 x 350 (13.8x13.8) or ø 400 (15.7)	mm (inch)	8		
400 x 400 (15.7x15.7) or ø 450 (17.7)	mm (inch)	6		
500 x 500 (19.7x19.7) or ø 550 (21.7)	mm (inch)	4		

WXH = 1,900 X 1,700 (74.8 X 66.9)

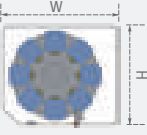

150 X 150 (5.9 X 5.9)    250 X 250 (9.8 X 9.8)    320 X 320 (12.6 X 12.6)    350 X 350 (13.8 X 13.8)    400 X 400 (15.7 X 15.7)    500 X 500 (19.7 X 19.7)

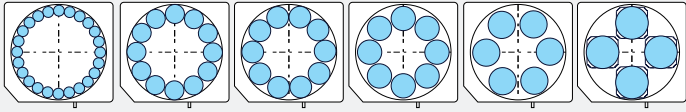
External Dimensions

Unit: mm (inch)

Top View

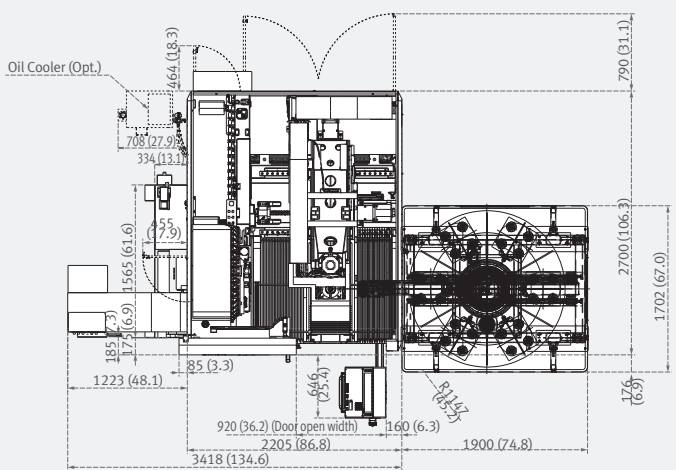

Oil Cooler (Opt.)

708 (27.9)    334 (13.1)    464 (18.3)    790 (31.1)    2700 (106.3)    1702 (67.0)    166 (6.5)    1900 (74.8)    2205 (86.8)    3418 (134.6)    920 (36.2) (Door open width)    160 (6.3)

Front View

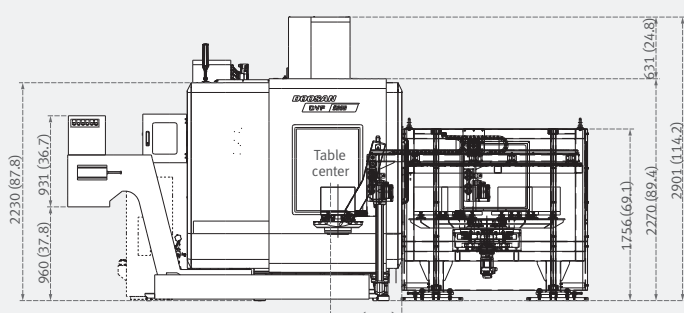

2230 (87.8)    960 (37.8)    931 (36.7)    1756 (69.1)    2270 (89.4)    2901 (114.2)    730 (28.7)

Table center

(1:20 rate)

## Cutting Performance

From high speed machining to heavy duty cutting, diverse machining operations are possible for a wide variety of complex workpiece shapes.

### Machining Performance

#### Max. chip throughput

Item	Material (SM45C)	Condition
Machining removal rate	599 cm <sup>3</sup> /min (36.6 inch <sup>3</sup> /min)	Ø80mm (3.15 in.) Face Mill (6Z)
feedrate	4680 mm/min (184.3 ipm)	
depth of cut	2 mm (0.1 inch)	
Item	Material (AL6061)	Condition
Machining removal rate	1814 cm <sup>3</sup> /min (110.7 inch <sup>3</sup> /min)	Ø80mm (3.15 in.) Face Mill (6Z)
feedrate	9450 mm/min (372.0 ipm)	
depth of cut	3 mm (0.1 inch)	

\* The results, indicated in this catalogue are provides as example. They may not be obtained due to differences in cutting conditions and environmental conditions during measurement.

### Machining Examples

Item	Door Handle (Aerospace)	
Material	Aluminum	
Cycle time	3 hour 30 min	
Tool	Ø12 (0.5) x R2 Endmill	
Spindle speed	8000 r/min	
Feed rate	1800 mm/min (70.9 ipm)	

### Ball Bar Measurement Test

Higher roundness accuracy is realized by the advanced design of machine structure and Doosan control system.

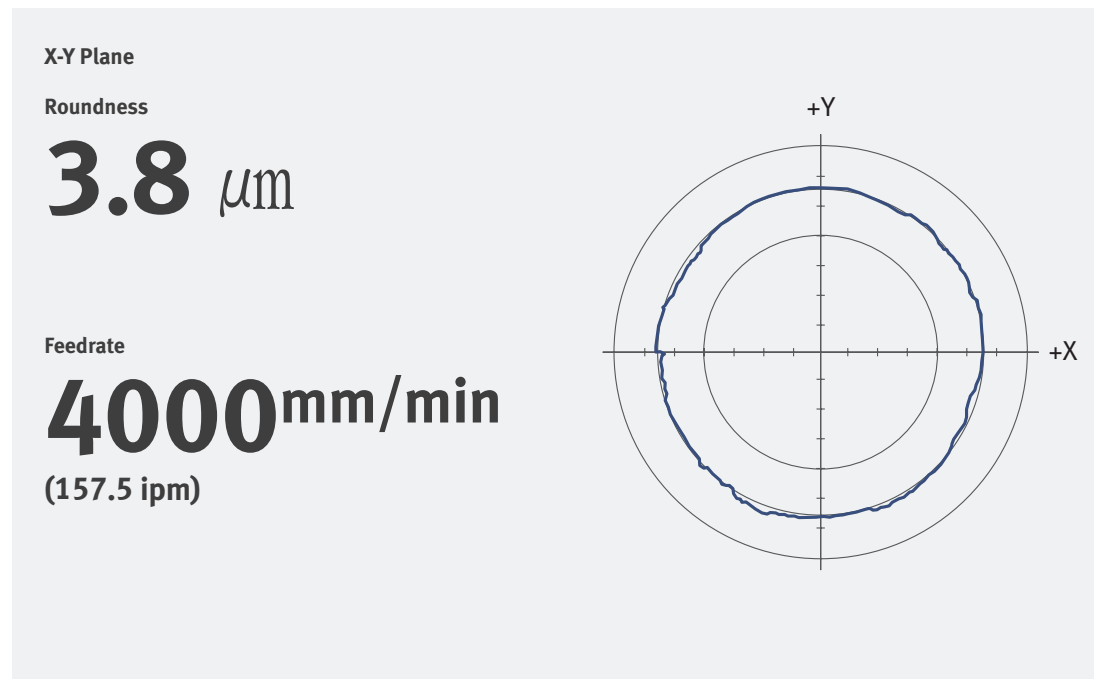



## Standard / Optional Specifications

● Standard ○ Optional X Not applicable

### Basic information

Basic Structure  
Cutting  
Performance

Various optional features are available to satisfy customers' specific machining applications.

### Detailed Information

Options  
CUFOS  
Applications  
Diagrams  
Specifications

### Customer Support Service

NO.	Description	Features	DVF 5000	
1	Spindle	12000 r/min	●	
2		18000 r/min	○	
3	Magazin	Tool storage capacity	30ea	
4			40 / 60 / 90 / 120ea	
5	Tool shank type	BIG PLUS BT40	●	
6		CAT40 / DIN / HSK A63	○	
7	Coolant	FLOOD	1.1 KW_0.7 MPA_30 L/MIN	
8		TSC	None	●
9			1.5 KW_2.0 MPA_BUILT-IN FILTER	○
10			2.2 KW_3.0 MPA_BUILT-IN FILTER	○
11			3.7 KW_7.0 MPA_BUILT-IN FILTER	○
12		OIL SKIMMER	None	●
13			BELT TYPE	○
14		Coolant level switch : Sensing level - Low / High**		
15		Chip disposal	Chip conveyor	CHIP PAN
16				HINGED BELT_LEFT SIDE
17			Chip bucket	Forklift type
18				Rotation type
19			Air gun	
20		Coolant gun		
21	Precision machining options	Linear scale	X / Y / Z axis	
22	Measurement & Automation	IKC READY	S/W ONLY	
23			RENISHAW (RMI-Q) + S/W	
24			HEIDENHAIN (SE660) + S/W	
25			BLUM (RC66) + S/W	
26		DATUM BALL FOR IKC	NONE	
27			DATUM BALL_D25	
28		TOUCH PROBE FOR IKC	NONE	
29			RMP60_RENISHAW	
30			TS460_HEIDENHAIN	
31			TC60_BLUM	
32			Automatic tool measurement	NONE
33		TS27R_RENISHAW		
34		RTS_RENISHAW		
35		NC4S_RENISHAW		
36		TT160_HEIDENHAIN		
37		ZX SPEED_BLUM		
38		MASTER TOOL	NONE	
39			MASTER TOOL	
40		Others	LED Work light	
41	3 Color signal tower			
42	Tool load monitoring			
43	EZ Guide i			
44	Automatic power off			
45	Customized special option	Front_ Auto door (w/saftey edge)	-	
46		Right side_ Auto door (w/saftey edge)	-	
47		Roof_ Auto door	-	
48		15K Directed connected spindle	BT / CAT / DIN / HSK	
49		Automatic workpiece changer	4 / 6 / 8 / 10 / 12 / 24	
50		Rotary joint for table	Fixture line thru rotary table center (Max.HYD 4port & PNE 2port)	
51		Paper filter with TSC	20 / 30 / 70 BAR	
52		IKC(Intelligent Kinematic Compensation)	DCP-i	
53	Kinematic OPT.			

\* Please contact DOOSAN to select detail specifications. \*\* Special Quotation.



## Peripheral Equipment

### Tool length measuring

#### Maximum workpiece limit

Automatic tool breakage detection (Touch type)

**Ø550 x 240 mm** (21.7 x 9.4 inch)

Automatic tool breakage detection (Laser type / Rotating touch type)

**Ø550 x 450 mm** (21.7 x 17.7 inch)

#### Limited use of Max workpiece



Renishaw(TS27R)



Heidenhain (TT160)



Blum (ZXSpeed)

#### Non Limited use of Max workpiece



Renishaw(NC4S)

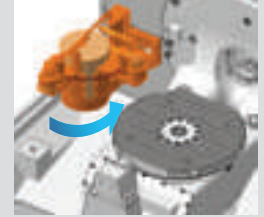

\* When using Tool Length Measurement, contact Doosan for detailed capacity diagram

### Intelligent Kinematic Compensation for 5-axis

For high accuracy 5 axis machining, Intelligent Kinematic Compensation function is recommended. This function minimizes error in complex 5 axis machining applications by maintaining the tool point in the correct position relative to the workpiece. In order to use this function, the following optional items are required.

#### Recommended optional items

##### 1. Software

FANUC NC: DCP-i (Developed by DOOSAN)



Heidenhain NC: Kinematic opt

##### 2. Receiver

Recommended Option



##### 3. Touch Probe

Recommended Option



##### 4. Datum ball

Recommended Option



##### 5. Automatic Tool Measurement

Recommended Option



##### 6. Master Tool

Recommended Option



### AWC system option

The optimized solution to realize compact automation system through automatic work-piece change system.



# CUFOS

## Customized User-friendly Flexible Operation Solutions

CUFOS is a PC based control system created by Doosan Machine Tools. Equipped with intuitive user-friendly functions such as a smart phone screen and easy customization, CUFOS helps to improve operational efficiency and performance for the user.

### • Features of CUFOS

#### User-Friendly

- 19 inch Multi Touch Screen
- Multiple Apps such as –
  - CPS app (Collision Protection System)
  - Turn-cut app
  - Tool management app
  - Status monitoring and alarm guidance app
- Max. program memory : 40GB option
- App-based Interface for Smartphones & Tablet PC

#### Customized

- Simple Customization
- Extend Functionality with Additional apps
- Register for up to 6 individual users

#### Flexible

- Simple Connectivity with External Software (Cloud, Office etc.)
- SSD data server app
- PC based operating system (Windows®7)



# CUFOS Interface

## User-Friendly Interface

CUFOS, the PC-based control created by Doosan Machine Tools, is an integrated system solution using an intuitive 19 inch touch screen. The system provides a convenient operator interface, a high level of customization and many useful high technology apps.

**Intuitive operation via the touch screen**  
Simple customization is available for customers' work environment.





Supports various Apps in three fields – Setup/Machining/Utility. It provides easy configuration by allowing the user to add and edit functions on the Home Screen according to job requirements.

## CUFOS Open CNC

### CUFOS operation for enhanced productivity

The CUFOS operating system is based upon the integration of all aspects of the manufacturing process, including setting, machining and maintenance. It consolidates up-to-date software technology created by Doosan Machine Tools, to improve overall efficiency and productivity. Using the system's modular construction, each function can be easily integrated with external PC software systems and applications, such as CAM and Tool Data systems.

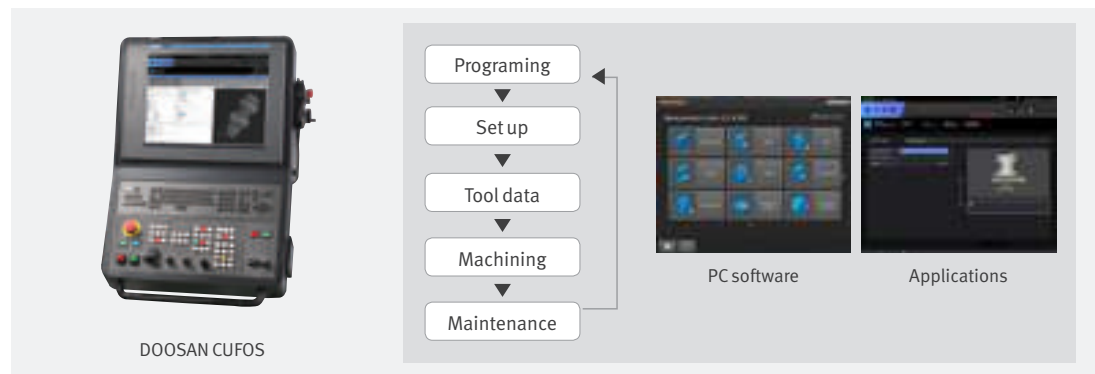

## CUFOS Machines

### Maximizing efficiency for multi-tasking machining

Applied to those multi-tasking turning center like PUMA SMX series as well as high performance, high productivity horizontal machining center NHP/NHM series, CUFOS maximizes the operational efficiency by adding up-to-date software technology of Doosan Machine Tools including new developed application such as CPS (Collision Protection System), Turn-cut, and the Tool Management function etc.





## Machining

### Basic information

Basic Structure  
Cutting  
Performance

### Detailed Information

Options  
CUFOS  
Applications  
Diagrams  
Specifications

### Customer Support Service

Reduce downtime and improve productivity by providing CPS(Collision Protection System), real-time status monitoring and maintenance guides during operating the machine



### CPS (Collision Protection System)

A function to prevent real-time collision in manual mode between the tool and equipment / machine elements inside the working area.

**Applicable models:**  
NHM/NHP/PUMA SMX series

- Supports Sandvik's cloud-based tool library for creation of 3D tool model

Use the Setup Manager with the CPS app to build up the machine model, and add tool, workpiece and workholding equipment details.

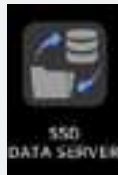
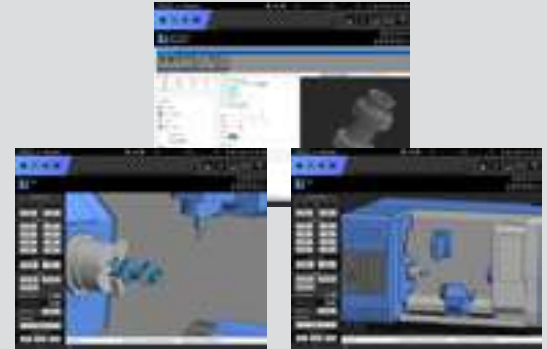

### SSD data server

As a PC based NC, it allows the HDD to be used as a storage space for machining program, saving time for program transfer.

**Applicable models:**  
NHM/NHP/PUMA SMX series

Max. storage size

**40GB\***

Max. file size

**2GB**

Max. file number

**Up to 1000**  
(including folder)

\* Max. storage size is determined by the size of SSD in Panel iHPro. If customer need Max. storage size of 40GB, it is necessary to select SSD129GB(option).



### NC control

Easy to convert the screen to standard FANUC format for operator convenience



### Status monitoring & Alarm guidance

Displays the cause and necessary action for NC/PMC alarms during machine running time. The system can send an email containing the alarm message if the condition persists for a specified time period.

**Applicable models:**  
NHM/NHP/PUMA SMX series



## Setup

Make easy & interactive guides to facilitate machining preparations such as setting materials, tool management and warming-up

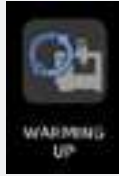

### Warming up

Automatically checks if a warm up process is required, and displays the required operator procedure graphically. The requirement is automatically determined by the machine status.

Applicable model:  
PUMA SMX series



Start warming up



Head tool change



Warming up completed



MDI mode



Cycle starting

## Utility

Support user convenience functions and additional software modules handling various peripheral devices like measurement



### Setting

CUFOS Provides management and setting functions such as HMI parameter / User setting / Setup manager / e-mail

### User setting

Allows the user to register and delete up to six persons from the user account. CUFOS apps and NC functions can be user-restricted as necessary.

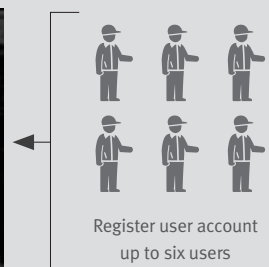

Register user account up to six users

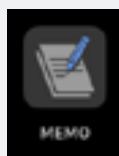

### Memo

Users can generate memos, either with a high level of detail via screen capture, or entered by keyboard/ touchscreen. The user can add data to existing memos if required

Maximum 120 memos can be saved



Memo



Screen capture

Memo through touch screen or key board or using a captured screen



Basic information

- Basic Structure
- Cutting
- Performance

Detailed Information

- Options
- CUFOS
- Applications
- Diagrams
- Specifications

Customer Support Service

Support user convenience functions and additional software modules handling various peripheral devices like measurement

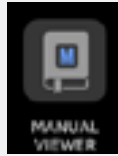

Manual viewer

Users can store and view manuals on the 19 inch screen.

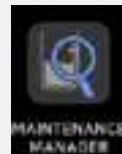

Maintenance manager

Monitors the status of machine and control elements, and confirms the alarm condition and maintenance schedule for preventative maintenance.

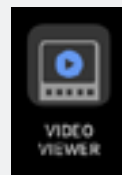

Video viewer

Video transfer and viewer functions make clearer communication possible between operators and helpful for training new workers, complex job arrangement

\* Video format : .wmv, .avi, .mpg, .mpeg, .mp2, mp3, .wav, .mov, .mp4 (same as Window media open files)





## Convenient Operation

Convenient and intuitive User interface.

### HEIDENHAIN TNC640

#### Superior Hardware Specifications

15 inch display and large capacity 21GB memory



15 inch display

Description	HEIDENHAIN	Remarks
Screen size	15" STD	-
Storage memory	21GB STD	-
Interference prevention system	Optional	-
Kinematic OPT.	Optional	Measuring device not included
Look-ahead block	1024 blocks	-
3D line graphics	Std.	-

### FANUC 31i5

#### User-Friendly Operation Panel

15inch display and user-friendly operating function ensure convenient and efficient operation.



15inch display

Design optimized for customers' needs based on extensive know-how

<b>Designed for user convenience</b>	Convenient and intuitive UI Optimized button size High-visibility lamps Long lifecycle buttons Partitioned to prevent operator error
<b>Convenient option buttons</b>	Detachable buttons Spare I/O signal ports for optional devices
<b>Customized functionality</b>	Customer-specific function switches Available for auxiliary panel design



## SIEMENS 840D

### Basic information

Basic Structure  
Cutting  
Performance

### Detailed Information

Options  
CUFOS  
Applications  
Diagrams  
Specifications

### Customer Support Service

SIEMENS CNC optimized for DOOSAN machine tools maximizes users' productivity.

### 15.6 inch screen + New OP

The newly-designed operation panel enhances operating convenience by incorporating common-design buttons and layout, and features the Qwerty keyboard for fast and easy operation.



**15.6-inch display**

- 10MB high capacity user memory
- USB & Ethernet (standard)
- QWERTY Keyboard (standard)
- High speed calculation and simulation can be fulfilled by improved processor skill

### Conversational Convenient function

The machining monitoring function developed on the basis of the Shop Mill – an interactive machining support function of SIEMENS – provides users with cutting, servicing and maintenance screens for easy and convenient machine operation.

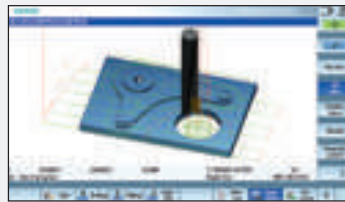

#### Simulation and machining contour monitoring

Simulation results with different views can be checked.

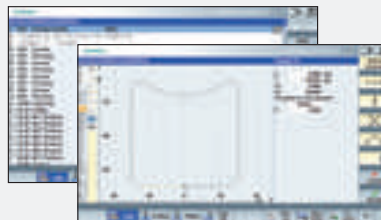

#### Shop Mill Part Programming

It helps to write the part program and shorten the writing time.

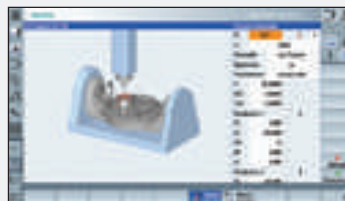

#### 5-axis kinematic measuring cycles

This function automatically measures and corrects the rotation axis center, increasing 5-axis machining accuracy.

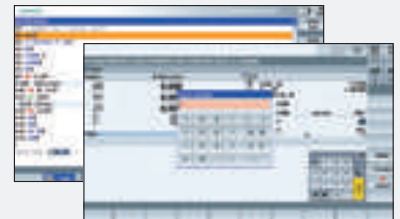

#### Smart function

Color highlighting is provided for each processing code function, and the calculator can be used easily by using the pocket calculator on display.



#### Side screen widget

Through the side widget, operator can easily monitor the current machining status.

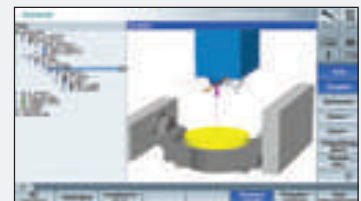

#### 3D Collision Avoidance\_Collision Avoidance ECO

Detect collisions in real time. Detection is possible in all operation modes.





## Easy Operation Package

The software developed by Doosan's own technology provides numerous functions designed for convenient operation.

### Easy Operation Package (EOP)

Setting up of tools, work pieces and programs, as well as troubleshooting for abnormal condition of main machine elements is designed to minimize waiting time, maximize operational efficiency, and enhance operator convenience.

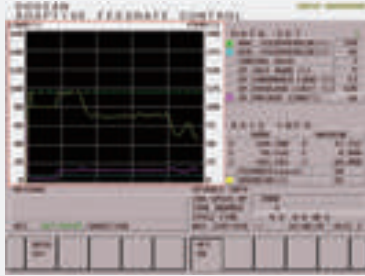

#### Adaptive Feed Control (AFC)

Function to control feedrate so that the cutting can be carried out at a constant load  
(To adapt to the spindle load set up with constant load feedrate control function)



#### Tool Management

Function to manage tool information  
[Tool information]  
- Tool No.  
- Tool condition : normal, large diameter, worn/damaged, used for the first time, manual  
- Tool name



#### Tool Load Monitor

Function to automatically monitor tool load  
(Different loads can be set for one tool according to M700 ~ M704)



#### Pattern Cycle (Engraving function : **option**)

Function to create frequently-used cutting programs automatically  
- Pattern Cycle: creates a program for a pre-defined shape  
- Engraving: creates a program for cutting a shape described with characters (option)



#### Work Offset Setting

Function to configure various work offset settings



#### Alarm Guidance

Function to show detailed info on frequently triggered alarms and recommended actions



#### Sensor Status Monitor

Function to view sensor conditions of the machine



#### ATC Recovery

Function to view detailed info with recommended actions and to perform step-by-step operation manually (when an alarm is triggered during an ATC operation)

## Power-Torque Diagram

### Basic information

Basic Structure  
Cutting  
Performance

### Detailed Information

Options  
CUFOS  
Applications  
Diagrams  
Specifications

### Customer Support Service

## FANUC

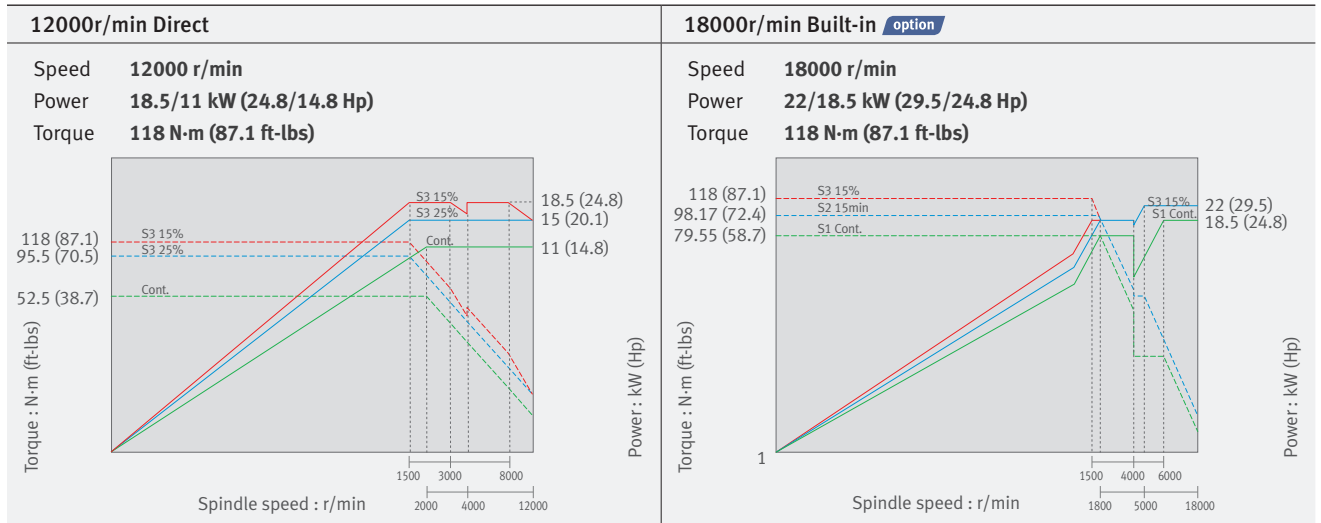

## HEIDENHAIN

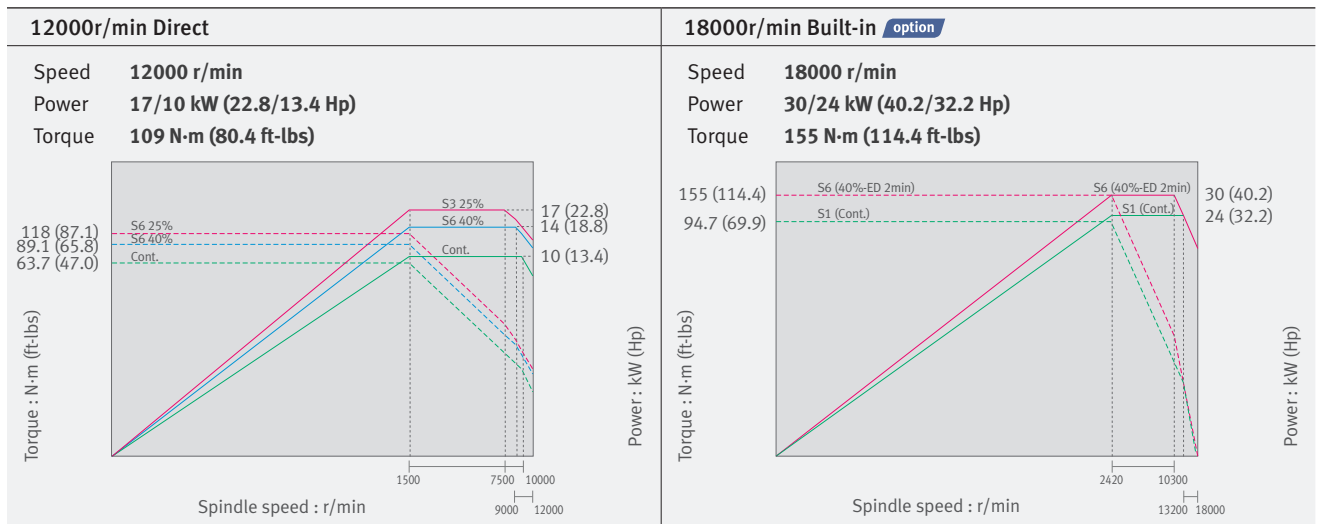

## SIEMENS

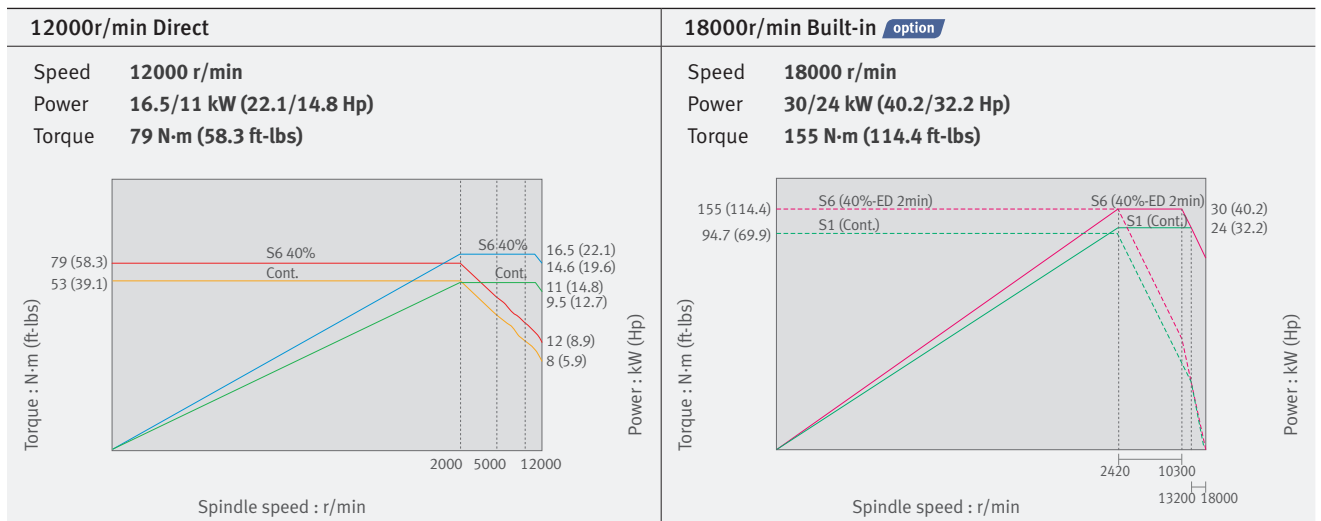

## External Dimensions

### DVF 5000

Unit : mm (inch)

Top View

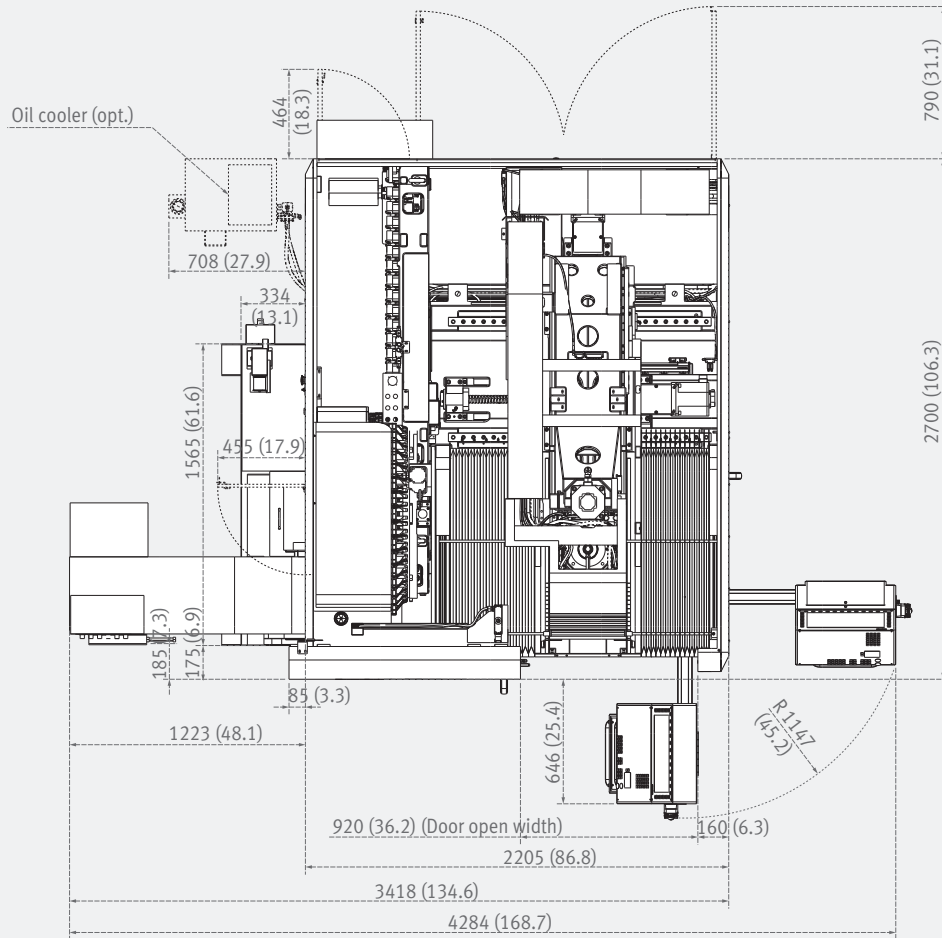

Front View

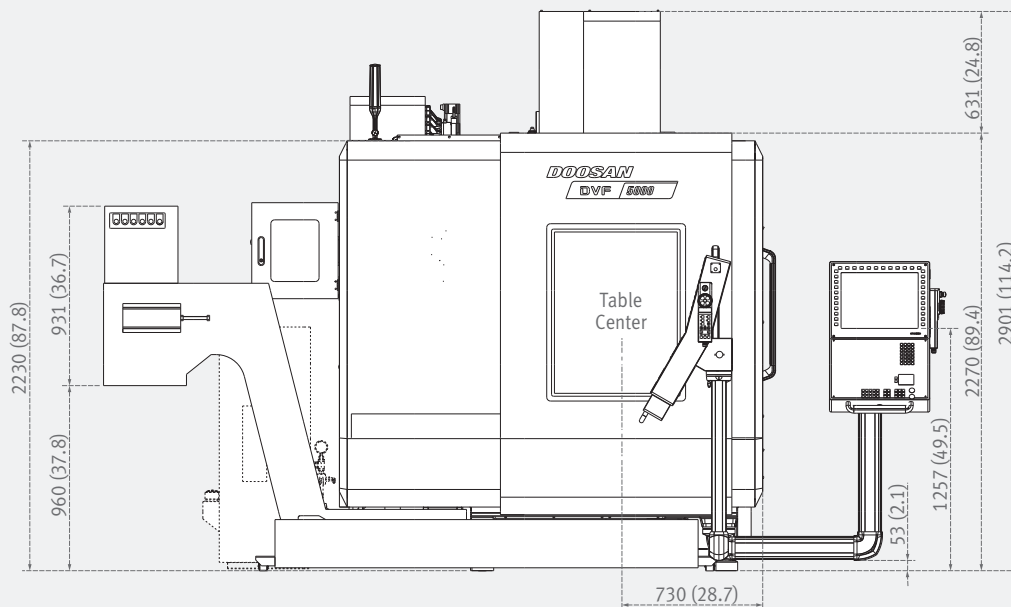

(1:20 rate)

\* Some peripheral equipment can be placed in other places

# Interference diagram

## Basic information

- Basic Structure
- Cutting
- Performance

## Detailed Information

- Options
- CUFOS
- Applications
- Diagrams
- Specifications

## Customer Support Service

# DVF 5000

Unit : mm (inch)

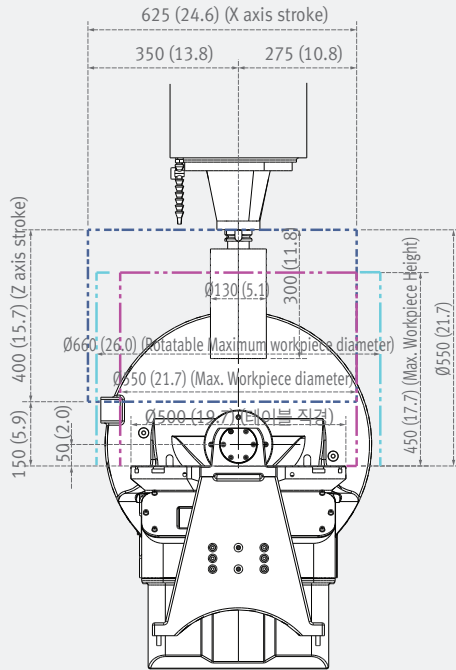

Front view (1:10)

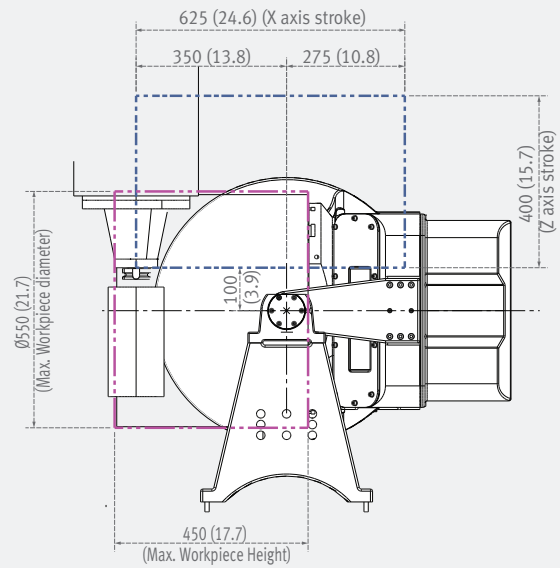

Front view (1:10)

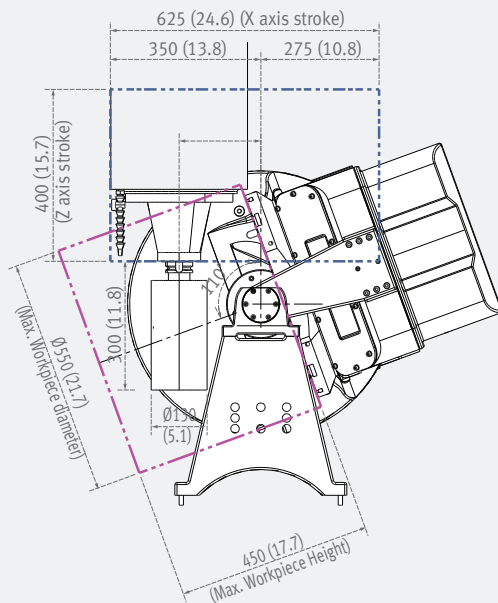

Front view (1:10)

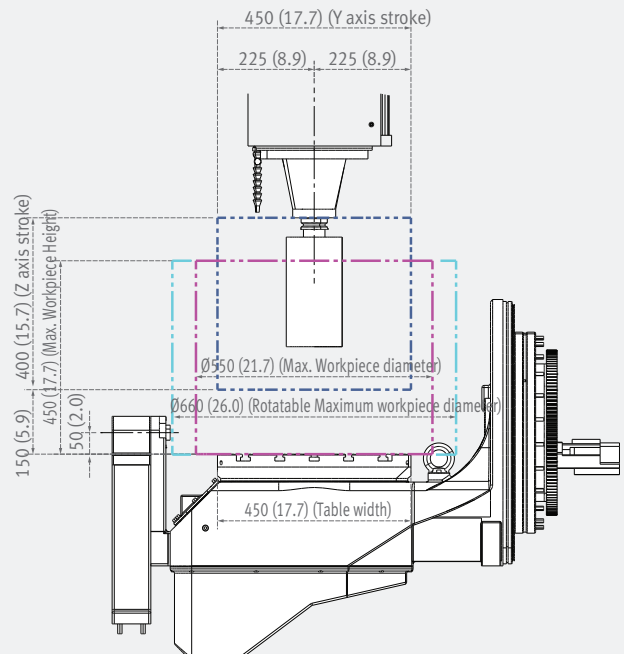

Right view (1:10)

## Machine Specifications



Description		Unit	DVF 5000	
Travels	Travel distance	X axis	mm (inch)	625 (24.6)
		Y axis	mm (inch)	450 (17.7)
		Z axis	mm (inch)	400 (15.7)
		B axis	deg	-30 ~ +110
		C axis	deg	360
Table	Table size		mm (inch)	∅ 500 x 450 {∅ 630 x 450}* (∅ 19.7 x 17.7 {∅ 24.8 x 17.7})
	Max. workpiece size		mm (inch)	∅ 550 x h 450 (∅ 21.7 x h 17.7)
	Table loading capacity		kg (lb)	400 (881.8)
Spindle	Max. spindle speed		r/min	12000 {18000}*
	Max. spindle power (S3/Cont.)		kW (Hp)	Fanuc : 18.5 {22}* (24.8 {29.5}) H/H : 17 {30}* (22.8 {40.2})
	Max. spindle torque		N-m (ft-lbs)	Fanuc : 118 {118}* (87.1 {87.1}) H/H : 109 {155}* (80.4 {114.4})
Feedrate	Rapid traverse rate	X axis	m/min (ipm)	40 (1574.8)
		Y axis	m/min (ipm)	40 (1574.8)
		Z axis	m/min (ipm)	40 (1574.8)
		B axis	r/min	20
		C axis	r/min	20
Automatic Tool Changer	Type of tool shank	Tool shank	-	ISO #40
	Tool storage capa.		ea	30 {40, 60, 90, 120}*
	Max. tool diameter	Continuous	mm (inch)	75 (3.0)
		Without adjacent tools	mm (inch)	125 (4.9)
	Max. tool length		mm (inch)	300 (11.8)
	Max. tool weight		kg (lb)	8 (17.6)
	Tool change (Tool-to-Tool)		sec	1.3
Tank capacity	Coolant tank capacity		L (gal)	410 (108.3)
Machine Dimensions	Height		mm (inch)	2890 (113.8)
	Length		mm (inch)	2205 (86.8)
	Width		mm (inch)	2700 (106.3)
	Weight		kg (lb)	7500 (16534.4)
Control	NC system		-	CUFOS / FANUC 31i5 / HEIDENHAIN TNC640 / SIEMENS S840D

\*{ } : Option

# NC Unit Specifications

● Standard ○ Optional X N/A

## Basic information

Basic Structure  
Cutting  
Performance

## Detailed Information

Options  
CUFOS  
Applications  
Diagrams  
Specifications

## Customer Support Service



No.	Item	Spec.	FANUC 31i5	
1	Controlled axes	5 (X, Y, Z, C, B)	X, Y, Z, C, B	
2	Additional controlled axes	5 axes in total	STD.	
3	Simultaneously controlled axes	Positioning(G00)/Linear interpolation(G01) : 3 axes	X	
4		Circular interpolation(G02, G03) : 2 axes	X	
5		Positioning(G00)/Linear interpolation(G01) : 4 axes		
6		Circular interpolation(G02, G03) : 2 axes		
7	Controlled axis	Positioning(G00)/Linear interpolation(G01) : 5 axes	●	
8		Circular interpolation(G02, G03) : 2 axes	●	
9		Control axis detach		
10		Backlash compensation		
11		Emergency stop / overtravel		
12		HRV control		HRV 3+
13		Least command increment		0.001 mm / 0.0001"
14		Least input increment		0.001 mm / 0.0001"
15		Increment system C		IS-C
16		Machine lock		all axes / Z axis
17		Mirror image		Reverse axis movement (setting screen and M - function)
18		Stored pitch error compensation		Pitch error offset compensation for each axis
19		Interpolation type pitch error compensation		
20		Inclined Rotary Axis Control		
21		Stored stroke check1		Overtravel controlled by software
22	Position switch			
23	Incremental pulse coder			
24	Absolute pulse coder			
25	Interpolation & Feed function	2nd reference point return	G30	
26		3rd / 4th reference return		
27		Circular interpolation	G02, G03	
28		Nano interpolation		
29		Inverse time feed		
30		Cylindrical interpolation	G07.1	
31		Linear interpolation	G01	
32		Helical interpolation		
33		Helical interpolation B	Only Fanuc 30i	
34		Smooth interpolation		
35	NURBS interpolation			
36	Exponential interpolation			
37	Involute interpolation			
38	Helical involute interpolation			
39	Bell-type acceleration/deceleration before look ahead interpolation			
40	Smooth backlash compensation			
41	Dwell	G04		
42	Exact stop check	G09, G61 (mode)		
43	Feed per minute	mm / min		
44	Feedrate override	0 - 200 % (10% unit)		
45	Jog override	0 - 200 % (10% unit)		
46	Automatic corner override	G62		
47	Automatic corner deceleration			
48	Cutting feedrate clamp			
49	Rapid traverse bell-shaped acceleration/ deceleration			
50	Interpolation & Feed function	Manual handle feed	Max. 3unit	
51		Manual handle feed rate	x1, x10, x100 (per pulse)	
52		Handle interruption		
53		Manual handle retrace		
54		Manual handle feed 2/3 unit		
55		Override cancel	M48 / M49	
56		Positioning	G00	
57		Rapid traverse override	F0 (fine feed), 25 / 50 / 100 %	
58		Reference point return	G27, G28, G29	
59		Skip function	G31	
60	Nano smoothing	AI contour control II is required.		
61	Nano smoothing 2	AI contour control II is required. Only Fanuc 31i-B5 and 30i		
62	AI APC	20 BLOCK		
63	AICC I	30 BLOCK		
64	AICC I	40 BLOCK		
65	AICC II	200 BLOCK		
66	AICC II	400 BLOCK		
67	High-speed processing	600 BLOCK		
68	Look-ahead blocks expansion	1000 BLOCK		
69	DSQ I	AICC II (200block) + Machining condition selection function		

# HEIDENHAIN

No.	Item	Spec.	TNC 640	
1	Controlled axis	3 axes	X	
2		Controlled axes	4 axes	X
3			5 axes	X, Y, Z, C, B
4		Additional controlled axes	6 axes	X
5		Simultaneously controlled axes	Controlled axes	●
6		Controlled axes	Max. 18 axes in total	OPT(Max. 18 axes)
7		Least command increment	0.0001 mm (0.0001 inch), 0.0001°	●
8		Least input increment	0.0001 mm (0.0001 inch), 0.0001°	●
9		Maximum commandable value	±99999.999mm (±3937 inch)	●
10		Axis feedback control	Double-speed control loops for high-frequency spindles and torque/linear motors	○
11		MDI / DISPLAY unit	15.1 inch TFT color flat panel	●
12			19 inch TFT color flat panel	○
13		Program memory for NC programs	SSDR	21GB
14		Block processing time		0.5 ms
15		Cycle time for path interpolation	CC 61xx	3 ms
16		Encoders	Absolute encoders	EnDat 2.2
17		Interpolation	Straight line	5 AXES
18	Circle		3 axes	
19	Helix, Combination of circular and linear motion		●	
20	Spline interpolation		●	
21	Configuration	Numerical structure	X	
22		Machine parameters	Tree structure with symbolic names of the parameters	●
23			Tabular representation	X
24	Commissioning and diagnostics	Integrated oscilloscope	●	
25		OnLine monitor (OLM)	●	
26		BUS diagnostics	●	
27		DriveDiag	●	
28		ApiData function	●	
29		Trace function	●	
30		Table function	●	
31		Logic diagram	●	
32		I/O-Force List	●	
33		Log	●	
34		Machine operating panel	TE 735	●
35			TE 745	○
36		Electronic handwheels	HR 410	●
37		Data interfaces	Ethernet interface	●
38	USB interface (USB 2.0)		●	
39	Feedrate override	0 - 150 % (10% unit)	●	
40	Spindle orientation		●	
41	Spindle speed command	S5 digits	●	
42	Spindle speed override	0 - 150 %	●	
43	Monitoring functions	Position monitoring	●	
44		Movement monitoring	●	
45		Standstill monitoring	●	
46		Positioning window	●	
47		Temperature monitoring	●	
48		Amplitude of encoder signals	●	
49		Edge separation of encoder signals	●	
50		Nominal speed value	●	
51		Buffer battery	●	
52		Run-time of PLC program	●	
53		Emergency-stop monitoring	●	
54	Internal power supply and housing fan	●		
55	Gantry axes and master-slave torque control		●	
56	Look-ahead (Intelligent path control by calculating the path speed ahead of time)	Max. 1024 blocks.	X	
57		Max. 5000 blocks.	●	
58	ADP (Advanced Dynamic Prediction)		●	
59	HSC filters		●	
60	Switching the traverse ranges		●	
61	C-axis operation	Spindle motor drives the rotary axis	●	
62	Program input	According to ISO	●	
63		With smarT.NC	X	
64		With smartSelect	●	
65	Position entry	Nominal positions for lines and arcs in Cartesian coordinates	●	
66		Incremental or absolute dimensions	●	
67		Display and entry in mm or inches	●	

# NC Unit Specifications

● Standard ○ Optional X N/A

**Basic information**

- Basic Structure
- Cutting
- Performance

**Detailed Information**

- Options
- Applications
- Diagrams
- Specifications

**Customer Support Service**



No.	Item	Spec.	S840D	
1	Controlled axis	Controlled axes	4 axes 5 axes	X X, Y, Z, C, B
2		Additional controlled axes	Max. 31 axes in total(S840Ds) /Max. 5 axes in total(S828D)	○
3		Simultaneously controlled axes	Positioning(G00)/Linear interpolation(G01) : 5 axes Circular interpolation(G02, G03) : 2 axes	●
4		Backlash compensation		●
5		Emergency stop / overtravel		●
6		Least command increment	0.001mm (0.0001 inch)	●
7		Least input increment	0.001mm (0.0001 inch)	X
8		Least input increment	0.0001mm (0.0001 inch)	●
9		Maximum commandable value	±99999.999mm (±3937 inch)	●
10		Machine lock (PRT)	All axes	●
11		Position switching signals/cam controller		●
12		Absolute encoder		●
13		Travel to fixed stop with Force Control		○
14		Dry run		●
15		Interpolation & Feed Function	Feedrate/Rapid override	0 - 120 %
16	Reference point return		G75 FP=1	●
17	2nd reference point return		G75 FP=2	●
18	3rd / 4th reference return		G75 FP=3, 4	●
19	Advanced surface			●
20	Top surface			○
21	Linear interpolation		Max. 4	●
22	Circular interpolation		G02, G03	●
23	Inverse time feedrate		G93	●
24	Helical interpolation			●
25	Universal interpolator NURBS			●
26	Polynomial interpolation			○
27	Spline interpolation (A, B and C splines)			●
28	Spindle & M code Function	Involute interpolation		○
29		Dwell	G04	●
30		Separate path feed for corners and chamfers		●
31		Reposition		●
32		Acceleration with Jerk limitation		●
33		Compressor for 3-axis machining		●
34		Compressor for 5-axis machining		●
35		Temperature compensation		●
36		Positioning	G00	●
37		Look ahead number of block	S/W version 4.5 S/W version 4.7 S/W version 4.8	150 1000 1000
38		Cartesian point-to-point (PTP) travel		●
39		TRANSMIT/cylinder surface transformation		●
40		Inclined axis		X
41	Inclined axis TRAANG after TRANSMIT/TRACYL		●	
42	Tool Function	Spindle speed, digital setpoint		●
43		Spindle speed, max. programmable value range	106 ... 0.0001 (display: ± 999999999.9999)	●
44		Spindle override	50 - 120 %	●
45		Automatic gear state selection		●
46		Oriented spindle stop		●
47		Spindle speed limitation min./max.		●
48		Constant cutting rate		●
49		Spindle control via PLC (Positioning, oscillation)		●
50		Changeover to axis mode		●
51		Tapping with compensating chuck/rigid tapping		●
52		Tool radius compensations in plane	With approach and retract strategies With transition circle/ellipse on outer edges	● ●
53		3D Tool radius compensation		●
54		Number of tools/cutting edges in tool list	256/512 600/1500	X ●
55	Tool length compensation		●	
56	Operation with tool management		●	
57	Tool list		●	
58	Tool offset selection via T and D numbers		●	
59	Replacement tools for tool management		●	
60	Monitoring of tool life and workpiece count		●	
61	Manual measurement of tool offset		●	
62	Programming & Editing Function	Programming language (DIN 66025 and high-level language expansion)		●
63		Main program call from main program and subprogram		●
64		Subprogram levels and interrupt routines, max.		16/2
65		Number of subprogram passes ≤ 9999		●
66		Number of levels for skip blocks		8
67		Number of levels for skip blocks, maximum 10		X
68		Polar coordinates		●
69		1/2/3-point contours		●
70		Dimensions metric/inch, changeover manually or via program		●
71		Auxiliary function output	Dynamic preprocessing memory FIFO Via H word, max. range: REAL ± 3.4028 ex 38, INT -231 ... 231-1	●
72		CNC High-level language with	User variables, configurable	●
73			Read/write system variables	●
74			Indirect programming	●
75	Program jumps and branches		●	
76	Program coordination with WAIT, START, INIT		●	
77	Arithmetic and trigonometric functions		●	
78	Compare operations and logic combinations		●	
79	Macro techniques	●		
80	Control structures IF-ELSE-ENDIF	●		
81	Control structures WHILE, FOR, REPEAT, LOOP	●		
82	STRING functions	●		



No.	Item	Spec.	S840D
89	Program functions	Dynamic preprocessing memory FIFO	●
90		Frame concept	●
91		Inclined-surface machining with swivel cycle	●
92		Axis/spindle replacement	●
93		Geometry axes, switchable online in the CNC program	●
94		Program preprocessing	●
95	Online ISO dialect interpreter	●	
96	Program/workpiece management	Parts programs on (PPU or NCU), max. number	1000
97		Workpieces on (PPU or NCU), max. number	250
98		Workpieces on Hard disk, max. number	○
99		In additional HMI user memory on CF card	●
100		On additional plug-in CF card	X
101		On integral Hard disk PCU50.5	○
102		On USB storage medium (e.g. disk drive, USB stick)	●
103		On network drive	●
104		Templates for workpieces, programs and INI files	●
105		Job lists	●
106	Basic frames, max. number	16	
107	Settable offsets, max. number	G54, G55, G56 ...	
108	Zero/work offsets, programmable (frames)	●	
109	Scratching, determining zero/work offset	●	
110	Work offsets, external via PLC	●	
111	Global and local user data	●	
112	Global program user data	●	
113	Display system variables	○	
114	Program editor	Programming support for cycles program (Program Guide)	●
115		Dual editor	●
116		CNC editor with editing functions: Marking, copying, deleting	●
117		Programming graphics/free contour input (contour calculator)	●
118		Screens for 1/2/3-point contours (contour definition programming)	●
119		Support for parameter input Animated Elements	●
120		Shopturn/ShopMill Machining step programming	●
121		Technology cycles for drilling/milling	●
122		Pocket milling free contour and islands stock removal cycle	●
123		Residual material detection	●
124	Access protection for cycles	○	
125	Programming support can be extended, e.g. customer cycles	●	
126	Quick view for mold making program	●	
127	2D simulation	●	
128	3D simulation, finished part	●	
129	Simultaneous recording	●	
130	Measure kinematics	●	
131	DXF Reader for PC integrated in SINUMERIK Operate	○	
132	Others functions (Operation, setting & Display, etc)	Handwheel selection	●
133		Switchover: inch/metric	●
134		Manual measurement of zero/work offset	●
135		Manual measurement of tool offset	●
136		Automatic tool/workpiece measurement	●
137		Reference point approach, automatic/via CNC program	●

No.	Item	Spec.	S840D
138	MDA	Input in text editor	●
139		Save MDA program	●
140		Input screen forms for technology and positioning, cycle support	●
141	Teach-in		●
142	Automatic	Execution from USB interface on operator panel front	●
143		Execution from HMI memory on NCU CF card	●
144		Execution from network drive	●
145		Execution from Hard disk (PCU50.5)	○
146		Program control	●
147		Program editing	●
148		Overstoring	X
149		DRF offset	●
150		Block search with/without calculation	●
151		CNC user memory expanded for programs	< 100MB
152	Execution from external storage EES		○
153	Repos (repositioning on the contour)	With operator command/semi-automatically	●
154		Program-controlled	●
155	Preset	Set actual value	●
156	15.6" color display with touch screen		●
157	18.5" color display with touch screen		○
158	Plain text display of user variables		●
159	Multi-channel display		○
160	Others functions (Operation, setting & Display, etc)	2D representation of 3D protection areas/work areas	●
162		Access protection, 7 levels	●
163	Operating software languages	Ch_S, En, Fr, Gr, It, Sp	●
164		Ch_T, Kr, Pt	○
165		Additional languages, use of language extensions	○
166	Working area limitation		●
167	"Limit switch monitoring		●
168	(Software and hardware limit switches)"		●
169	Axis limitation from the PLC		●
170	Alarms and messages		●
171	Action log can be activated for diagnostic purposes		●
172	PLC status		○
173	Remote Control System (RCS) remote diagnostics	RCS Host remote diagnostics function	●
174		RCS Commander (viewer function)	●
175	Integrated service planner for the monitoring of service intervals		●
176	Automatic measuring cycles		X
177	Easy Extend		○
178	Contour handwheel		●
179	Integrate screens in SINUMERIK Operate with SINUMERIK Integrate Run MyScreens		●
180	Cross-mode actions (ASUPs and synchronized actions in all operating modes)		●
181	Axis collision protection PROT		●
182	Collision avoidance ECO (machine, working area)		○
183	MDynamics 3-axis		X
184	MDynamics 5-axis		●

Basic information

- Basic Structure
- Cutting
- Performance

Detailed Information

- Options
- CUFOS
- Applications
- Diagrams
- Specifications

Customer Support Service

# Responding to Customers Anytime, Anywhere

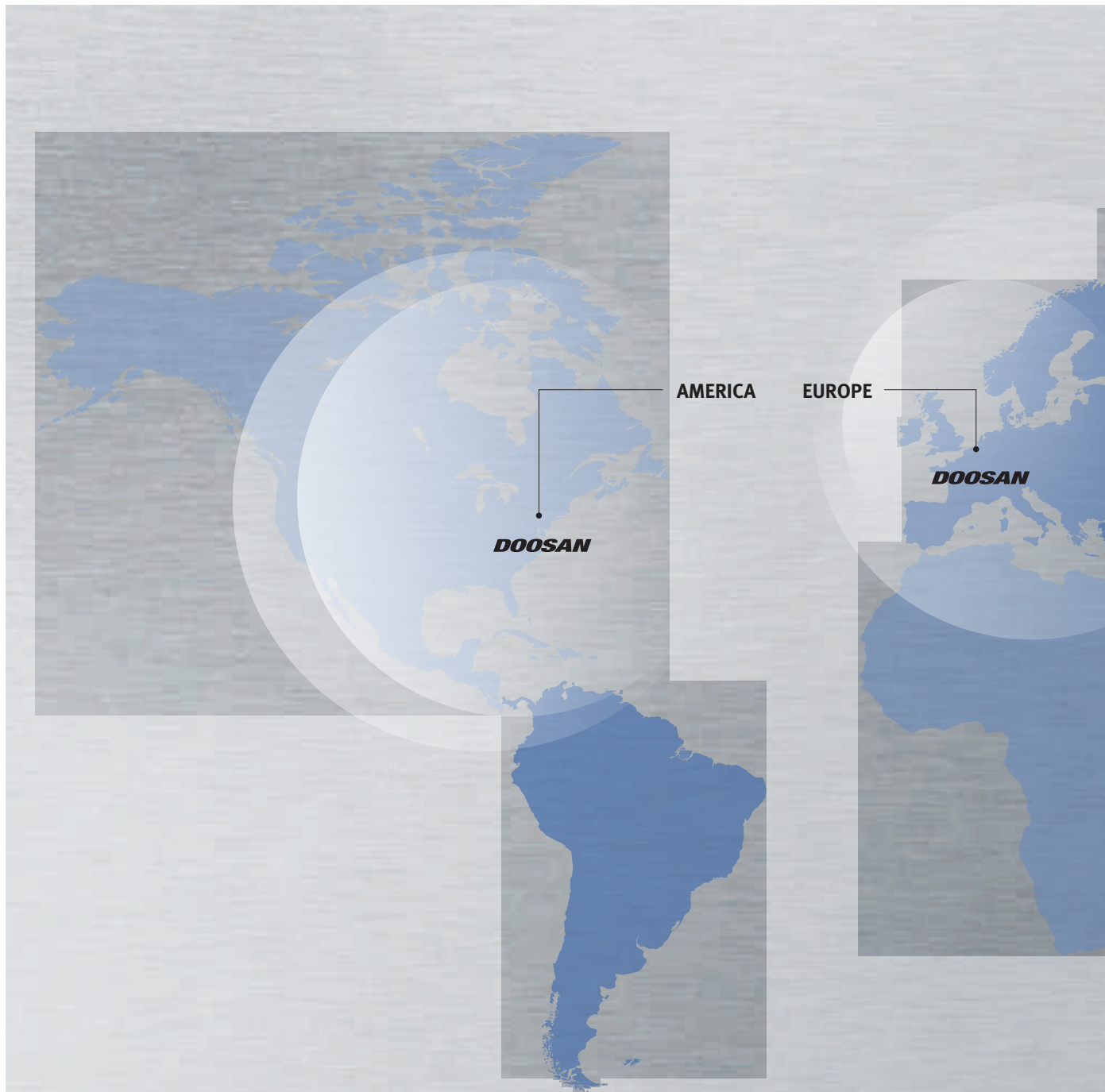

## Global Sales and Service Support Network

Corporations	Dealer Networks	Technical Centers	Service Post	Factories
4	164	51	198	3

Technical Center: Sales Support, Service Support, Parts Support

## Doosan Machine Tools' Global Network, Responding to Customer's Needs nearby, Anytime, Anywhere

Doosan machine tools provides a system-based professional support service before and after the machine tool sale by responding quickly and efficiently to customers' demands.

By supplying spare parts, product training, field service and technical support, we can provide top class support to our customers around the world.

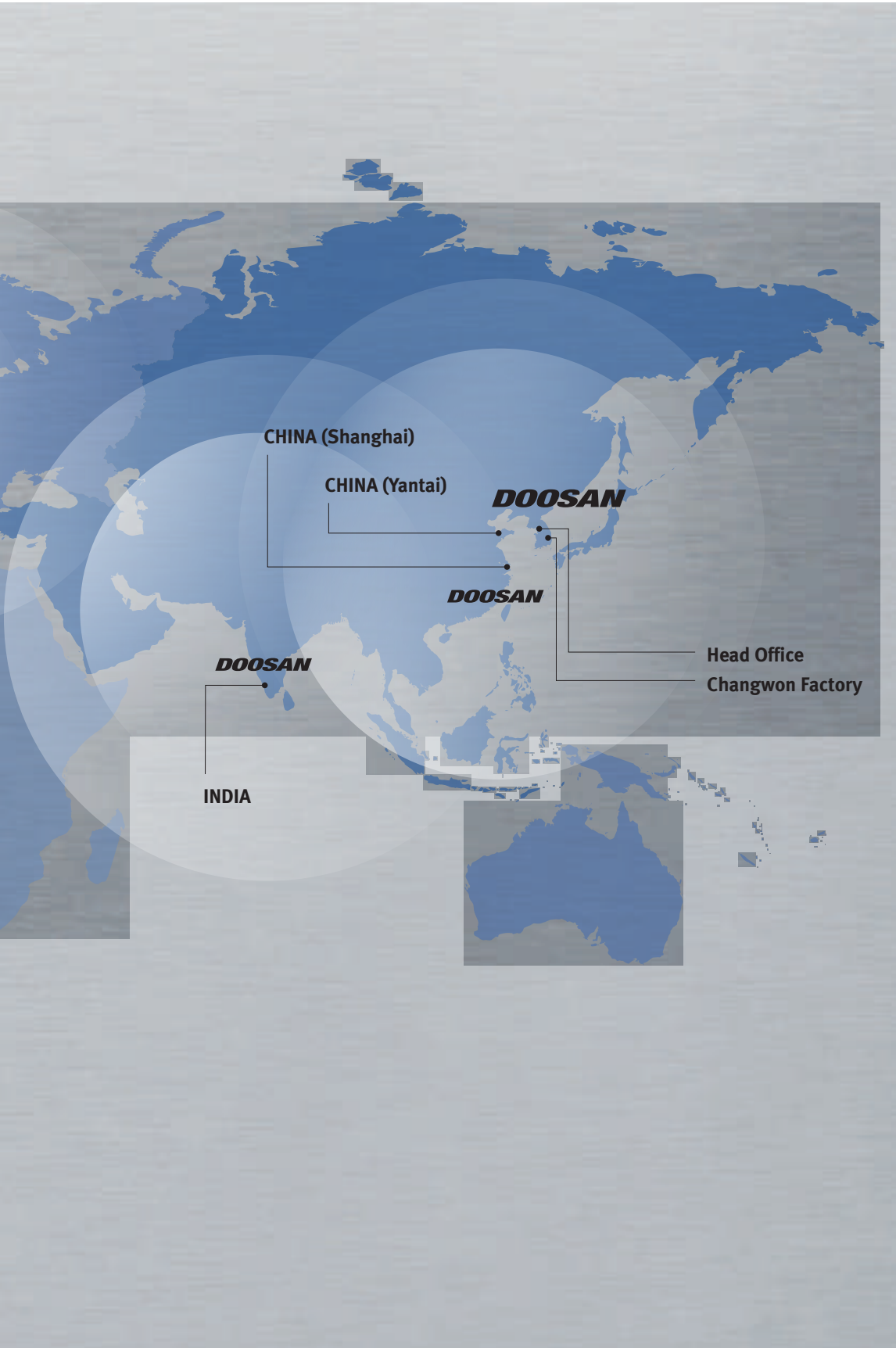

---

### Customer Support Service

We help customers to achieve success by providing a variety of professional services from pre-sales consultancy to post-sales support.

---

### Supplying Parts



- Supplying a wide range of original Doosan spare parts
- Parts repair service

---

### Field Services



- On site service
- Machine installation and testing
- Scheduled preventive maintenance
- Machine repair

---

### Technical Support



- Supports machining methods and technology
- Responds to technical queries
- Provides technical consultancy

---

### Training



- Programming / machine setup and operation
- Electrical and mechanical maintenance
- Applications engineering

## Major Specifications

### DVF 5000



Description		Unit	DVF 5000	
Travel	Travel distance	X-axis	mm (inch)	625 (24.6)
		Y-axis	mm (inch)	450 (17.7)
		Z-axis	mm (inch)	400 (15.7)
		B-axis	deg	-30 ~ +110
		C-axis	deg	360
Feedrate	Rapid traverse	X-axis	m/min (ipm)	40 (1574.8)
		Y-axis	m/min (ipm)	40 (1574.8)
		Z-axis	m/min (ipm)	40 (1574.8)
		B-axis	r/min	20
		C-axis	r/min	20
Spindle	Max. Spindle Speed		r/min	12000 {18000}*
	Max. Spindle Power		kW (Hp)	Fanuc : 18.5 {22}* (24.8 {29.5}) H/H : 17 {30}* (22.8 {40.2})
	Max. Spindle Torque		N·m (lb·ft)	Fanuc : 118 {118}* (87.1 {87.1}) H/H : 109 {155}* (80.4 {114.4})
	Tool shank		-	ISO #40
Table	Table size		mm (inch)	∅ 500 x 450 {∅ 630 x 450}* (∅ 19.7 x 17.7 {∅ 24.8 x 17.7})
	Max. Work size		mm (inch)	∅ 550 x h 450 (∅21.7 x h 17.7)
	Max. Work load		kg (lb)	400 (881.8)
ATC	Tool capacity		ea	30 {40, 60, 90, 120}*
Machine Dimensions	Length x Width		mm (inch)	2205 x 2700 (86.8 x 106.3)

\*{ } Option

## Doosan Machine Tools

www.doosanmachinetools.com



### Head Office

22FT Tower, 30, Sowol-ro 2-gil, Jung-gu,  
Seoul, Korea, 04637

Tel +82-2-6972-0370 / 0350

Fax +82-2-6972-0400

### Doosan Machine Tools America

19A Chapin Rd., Pine Brook, NJ 07058, U.S.A.

Tel +1-973-618-2500

Fax +1-973-618-2501

### Doosan Machine Tools Europe

Emdener Strasse 24, D-41540 Dormagen,  
Germany

Tel +49-2133-5067-100

Fax +49-2133-5067-111

### Doosan Machine Tools India

No.82, Jakkuar Village, Yelahanka Hobli,  
Bangalore-560064

Tel + 91-80-2205-6900

E-mail india@doosanmt.com

### Doosan Machine Tools China

Room 101,201,301, Building 39 Xinzhuang  
Highway No.258 Songjiang District, China  
Shanghai(201612)

Tel +86 21-5445-1155

Fax +86 21-6405-1472

\* For more details, please contact Doosan Machine Tools.

\* The specifications and information above-mentioned may be changed without prior notice.

\* Doosan Machine Tools Co., Ltd. is a subsidiary of MBK Partners. The trademark **DOOSAN** is used under a licensing agreement with Doosan Corporation, the registered trademark holder.

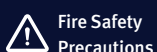

**Fire Safety  
Precautions**

There is a high risk of fire when using non-water-soluble cutting fluids, processing flammable materials, neglecting use coolants and modifying the machine without the consent of the manufacturer. Please check the SAFETY GUIDANCE carefully before using the machine.

ver. EN 200601 SU