



*Optimal Solutions for the Future*

# VC 630/5AX



---

**Simultaneous  
5-axis Vertical  
Machining Center**

---

**VC 630/5AX**

VC 630/5AX  
VC 630/5AX with APC

---

ver. EN 160623 SU

## Product Overview

### Basic Information

Basic Structure  
Cutting  
Performance

### Detailed Information

Options  
Capacity Diagram  
Specifications

### Customer Support Service



# VC 630/5AX

The VC630 5AX machining center provides full 5 axis simultaneous machining capability. It's highly rigid integral rotary/tilt table and high precision built in spindle provide the solution for both high speed and heavy duty machining of complex parts in one setting.



## Contents

### 02 Product Overview

#### Basic Information

### 04 Basic Structure

### 09 Cutting Performance

#### Detailed Information

### 10 Standard / Optional Specifications

### 14 Capacity Diagram

### 18 Machine / NC Unit Specifications

### 26 Customer Support Service

#### High-Rigidity Machine Structure

the highly rigid structure designed by 3D simulation techniques, and responsive axis feed system provide world class precision machining capability.

#### Built-in Spindle

The high performance built in spindle ensures optimum machining performance at high speed and heavy duty cutting.

#### Higher Machining Accuracy

For higher accuracy, we provide the thermal displacement compensation system even during a prolonged period of machining and high-rigidity machine structure.



## Basic Structure

High rigidity machine structure results in optimum static and dynamic rigidity verified by 3D simulation, resulting in highly stable precision machining.

## High-Rigidity Design and Structure

Machine structure is designed by Finite Element Analysis Method (FEM) and the static/dynamic rigidity is further enhanced.

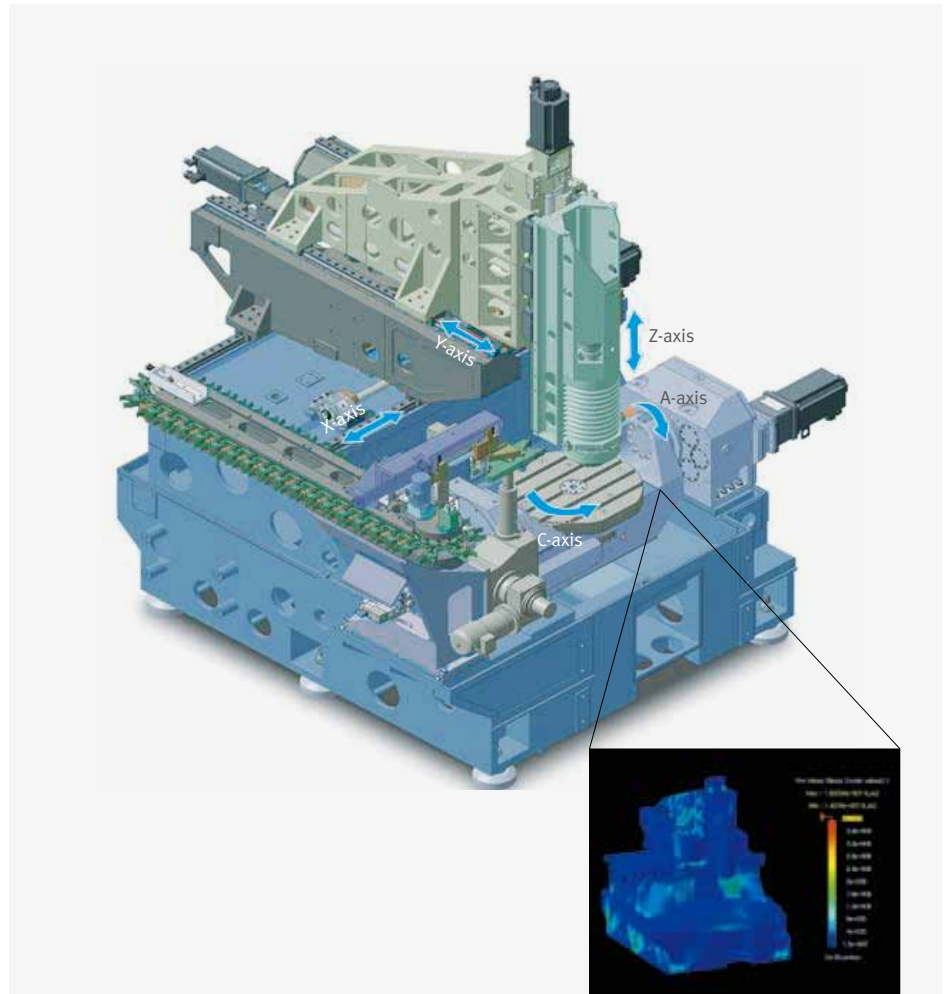

### Static Rigidity

The static rigidity structure of the VC630/5AX has been increased by 30% through the FEM analysis.

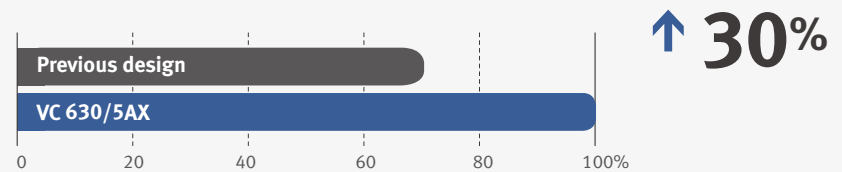

### Dynamic Rigidity

FEM analysis was also used to improve the frequency response and vibration damping property by 35% over the previous design.

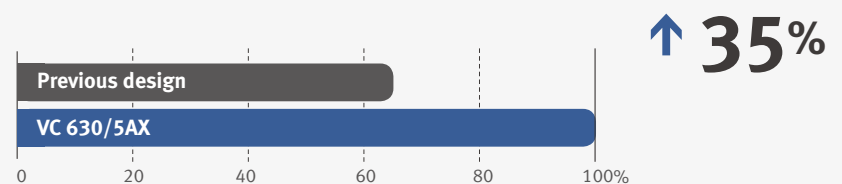

## Axis Feed System

### High-Rigidity Axis Feed System

The axis feed system structure is designed to achieve the combination of high rigidity and responsive feed motion. The base casting is made of heavy duty Meehanite Cast Iron which provides excellent vibration damping characteristics and guarantees highly stable machining conditions. Roller type linear guideways and highly rigid couplings are included to provide both rigidity and sensitive X,Y,Z axis feed. Ballscrew nut cooling reduces heat generation to minimise thermal displacement

#### High-rigidity roller type guideway

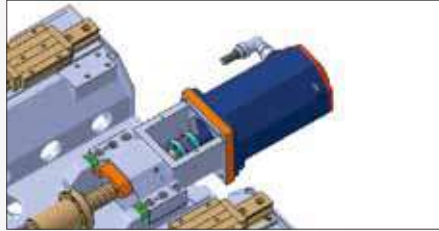

Rigidity and accuracy of feed system are improved with roller type guideway and coupling.



Roller type linear guideway

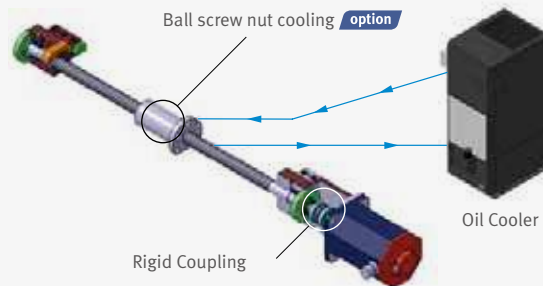

#### VC 630/5AX

Division	Unit	X-axis	Y-axis	Z-axis
Travels	mm (inch)	650 (25.6)	765 (30.1)	520 (20.5)
Rapid travers	m/min (ipm)	40 (1574.8)	40 (1574.8)	36 (1417.3)

### Linear scale option

All axes are equipped with the linear scale as an optional feature to maintain the highest degree of accuracy over many hours of operation.



### Thermal Error Compensation

live data is collected from multiple temperature sensors around the machine are combined with Doosan feed system smoothing algorithms to provide real time thermal compensation and provide optimum precision.

#### Heat displacement of VC630/5AX after compensation

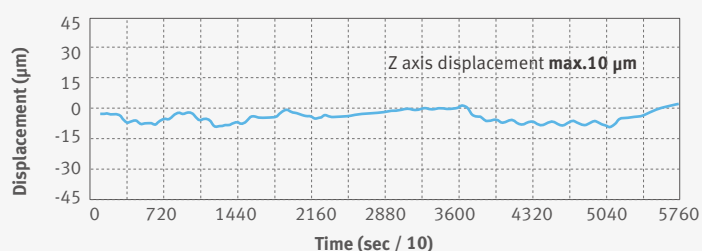



## Rotary Table

Large workpiece capacity allows a variety of parts to be machined in one set up.

### Max. Workpiece Size and Weight

Max. size

**ø730 x 500mm**  
(Ø28.7 x 19.7 inch)

Max. weight

**500kg**  
(1102.3 lb)

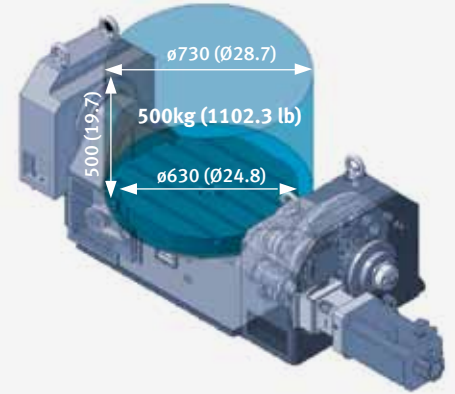

### Wider Machining Area

A wide machining area allows access to machine many features of large workpieces.

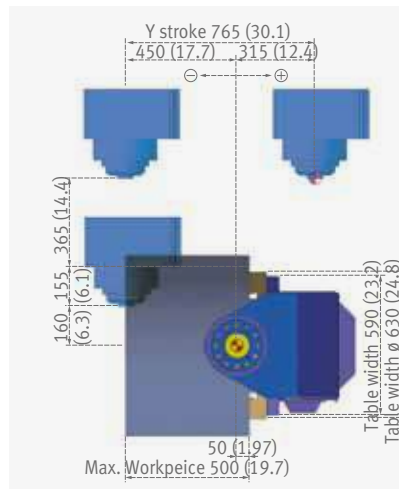

#### Stroke

Division		A-axis	C-axis
VC 630/5AX	Travels (deg)	+30 ~ -120	360
	Rapid traverse (r/min)	20	30

### Automatic Pallet Changer (APC) option

The automatic pallet changer allows setting the workpiece even during the machining process to further improve productivity.

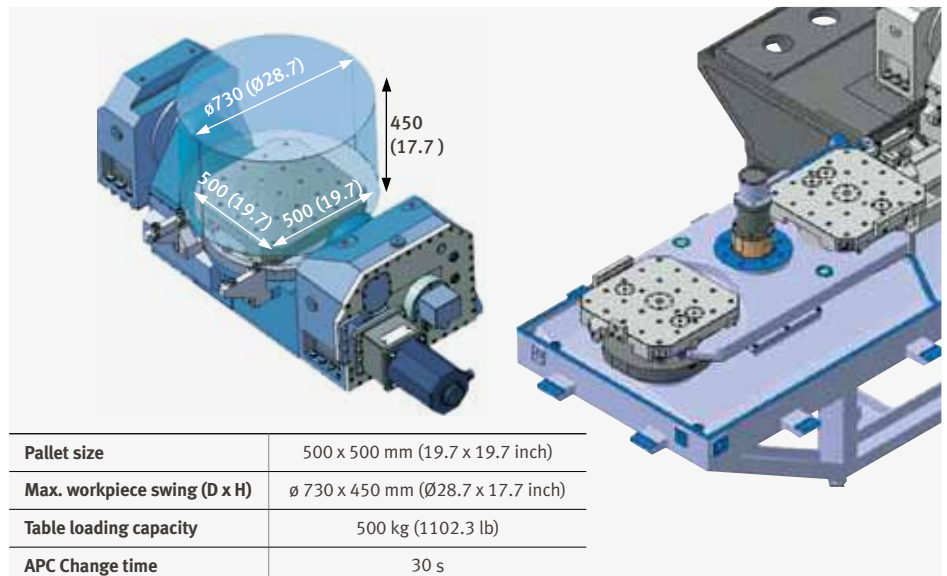

Pallet size	500 x 500 mm (19.7 x 19.7 inch)
Max. workpiece swing (D x H)	ø 730 x 450 mm (Ø28.7 x 17.7 inch)
Table loading capacity	500 kg (1102.3 lb)
APC Change time	30 s

## Tool Changer

Along with the rapid tool change that enables higher productivity, a wide range of choices is available for tool magazines.

### Automatic Tool Changer

Tool change time

**1.0<sup>s</sup>**

40 tools CAM Type ATC

(60, 81, 101, 121 tool) option

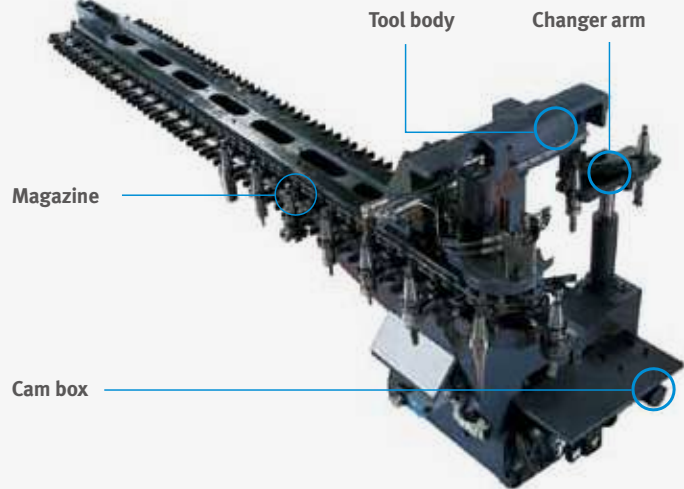

### High-Capacity Magazines option

A wide range of tool magazine choices (60 / 81 / 101 / 121 tools magazines) is available. The Increased tool capacity will improve user convenience and efficiency.

60 Tools

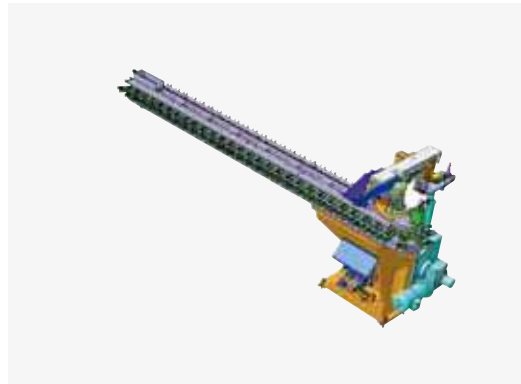

81 Tools

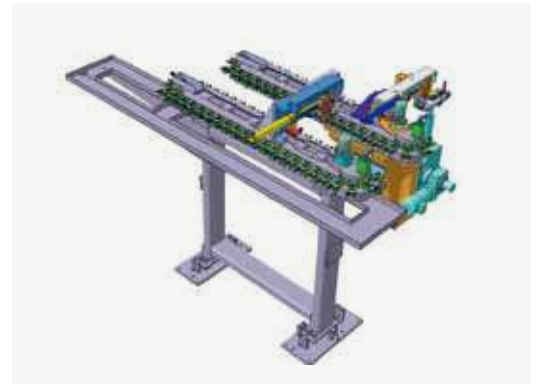

101 Tools

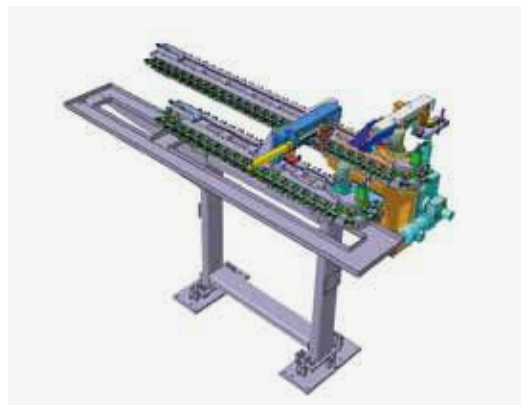

121 Tools



## Spindle

Built-in motor minimizes vibration and noise generated.

### Built-in Spindle

The main spindle is optimally designed with 4 row precision ceramic bearing whose features, low centrifugal force and minimum heat generation, are great merits at high speed condition. The high productivity is realized by reduction of the acceleration time to the maximum speed of main spindle.



### Spindle Motor

Spindle Motor Power Output (30min/cont. : 12000 r/min)

FANUC

**22/18.5 kW**  
(29.5/24.8 Hp)

HEIDENHAIN

**23.5/18 kW**  
(31.5/24.2 Hp)

SIEMENS

**30/24 kW**  
(40.3/32.2 Hp)

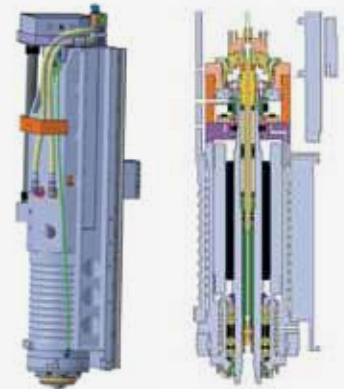

### Dual Contact Spindle

Dual contact spindle is adopted to improve spindle life and surface roughness in high-speed cutting process.

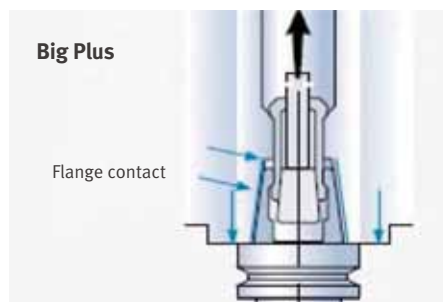



## Cutting Performance

From high-speed machining to heavy-duty cutting, diverse machining processes are applicable for complex-shaped workpiece.

## Machining Performance

### Max. chip throughput

Item	Material		Condition (SM45C, AL6061 same)
	SM45C	AL6061	
Machining removal rate	739.2 cm <sup>3</sup> /min	2688 cm <sup>3</sup> /min	Ø80mm (3.15 in.) Face Mill (6Z)
Feed rate	3300 mm/min (130 ipm)	7000 mm/min (275.8 ipm)	
Depth	2.5 mm (0.1 inch)	2.5 mm (0.1 inch)	
Width	64 mm (2.5 inch)	64 mm (2.5 inch)	

### Max. / min. tapping capabilities

Item	Material	
	SM45C	AL6061
Tool size	M42 x P4.5	M3 x P0.5
Feed rate	675 mm/min (26.6 ipm)	1800 mm/min (70.9 ipm)

\* The results, indicated in this catalogue are provides as example. They may not be obtained due to differences in cutting conditions and environmental conditions during measurement.

## Machining Examples

Tire Mold	
Workpiece size	400 x 400 x 150 mm (15.7 x 15.7 x 5.9 inch)
Material	Wood plastic
Mold Package	332 Tuning Cycle (Heidenhain Itnc530)
Cutting	Finish
Tool	Ø0.8mm Ball EM
Spindle speed	24000 r/min
Feed rate	400 mm/min (15.7 ipm)



Hinge Fitting	
Workpiece size	270 x 138 x 90 mm (10.6 x 5.4 x 3.5 inch)
Material	AL7075
Mold Package	DSQ 1
Cutting	Finish
Tool	Ø12 mm Ball EM
Spindle speed	12000 r/min
Feed rate	1000 mm/min (39.4 ipm)



Impeller	
Workpiece size	D290 x 153 mm (D11.4 x 6 inch)
Material	AL7075
Mold Package	DSQ 3
Cutting	Finish
Tool	Ø8 mm Ball EM
Spindle speed	12000 r/min
Feed rate	2500 mm/min (98.4 ipm)



## Ball Bar Measurement Test

Higher roundness accuracy is realized by the advanced design of machine structure and Doosan control system.

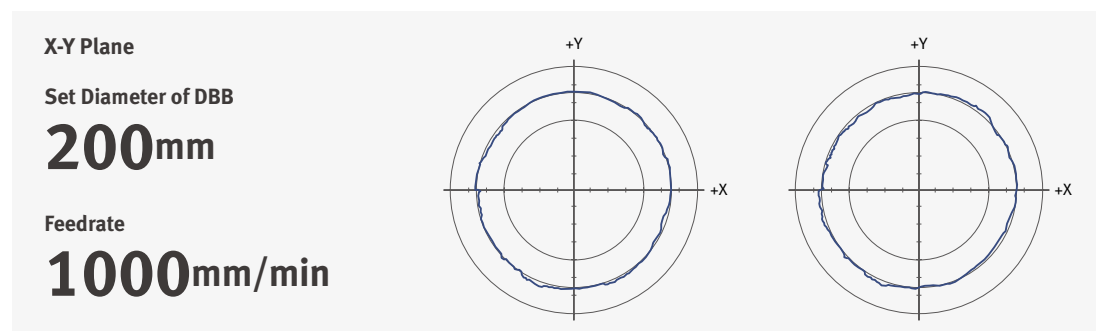

Product Overview



Standard / Optional Specifications

● Standard ○ Optional X N/A

Diverse optional features are available to meet specific customer requirements.

Basic Information

Basic Structure  
Cutting  
Performance

Detailed Information

Options  
Capacity Diagram  
Specifications





Customer Support Service

NO.	Description	Features	VC 630/5AX
1	Air blower		○
2	Air gun		○
3	Automatic tool changer	40 Tools	●
4		60 Tools	○
5		80 Tools	○
6		101 Tools	○
7		121 Tools	○
8	Automatic Tool Length Measurement	TS27R : RENISHAW	●
9	Chip conveyor	Hinge / Scraper / Drum filter type	○
10	Coolant gun		○
11	Coolant tank		●
12	DSQ (high speed / high precision contour control)	DSQ1 (AICC II_200 block)	●
13		DSQ2 (DSQ1 & Data server 1GB)	○
14		DSQ3 (DSQ2 & 600 block)	○
15		DSQ4 (DSQ3 & 1000 block)	○
16	Easy Operation Package (E.O.P)	Tool management system	●
17		Alarm / M-code / G-code / ATC restoration guidance	●
18		Table movement / Guidance on work coordinate system setup	●
19	Electric cabinet air conditioner		○
20	Electric cabinet light		○
21	Electric cabinet line filter		○
22	Linear scale	X Axis	○
23		Y Axis	○
24		Z Axis	○
25	MPG	1 MPG_PORTABLE TYPE	●
26		1 MPG_PORTABLE_W/ENABLE TYPE	○
27	NC system	DOOSAN FANUC i	○
28		FANUC 31i-5	●
29		HEIDENHAIN iTNC 530	○
30		SIEMENS S840Dsl	○
31	NC system lcd size	10.4 inch (Color)_DOOSAN FANUC i	○
32		15.0 inch (Color)_FANUC	●
33		15.0 inch (Color)_HEIDENHAIN	○
34		15.0 inch (Color)_SIEMENS	○
35	Oil Skimmer	Belt Type	○
36	Power transformer		○
37	Shower coolant		○
38	Spindle motor power	22/18.5 kW (29.5/24.8 Hp) : FANUC (12000, 20000 r/min)	●
39		23.5/18 kW (31.5/24.2 Hp) : HEIDENHAIN (12000 r/min)	○
40		28/24 kW (37.6/32.2 Hp) : HEIDENHAIN (20000 r/min)	○
41		30/24 kW (40.3/32.2 Hp) : SIEMENS (12000 r/min)	○
42	Spindle speed	12000 r/min	●
43		20000 r/min	○
44	Test bar		○
45	Through spindle coolant	NONE	●
46		1.5 KW_2.0 MPA	○
47		4.0 KW_2.0 MPA	○
48		5.5 KW_7.0 MPA_DUAL BAG FILTER	○
49	Work & tool counter	WORK / TOOL	○

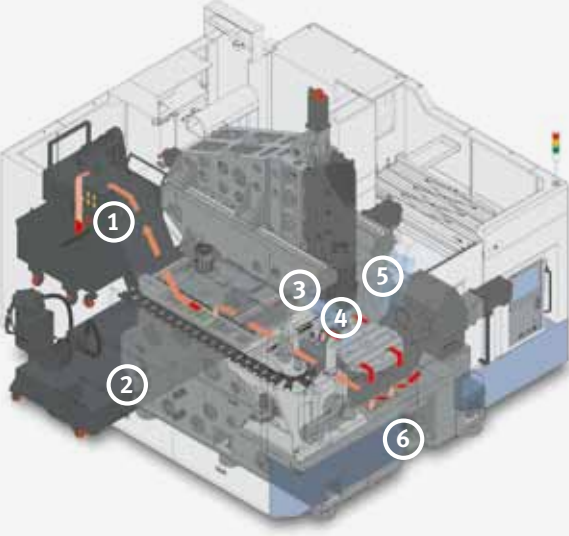
\* More options will require consultation with Doosan.

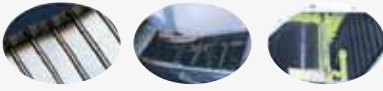
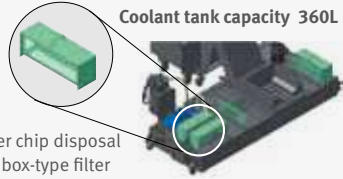
## Peripheral Equipment



<p><b>1. Chip conveyor</b> <small>option</small></p>  <p>Hinge type      Scraper type      Drum filter type</p>	<p><b>2. Large capacity coolant tank built-in with chip pan and box filter</b></p>  <p>Coolant tank capacity 360L</p> <p>Easier chip disposal with box-type filter</p>
<p><b>3. Shower coolant</b> <small>option</small></p> 	<p><b>4. Coolant system</b></p> 
<p><b>5. Auto-door type top cover</b></p> <p>The top cover helps enhancing convenience when loading/unloading heavy workpiece on the processing table.</p> 	<p><b>6. Internal screw conveyor</b></p> 

### Intelligent Kinematic Compensation for 5-axis Recommended Option

For high accuracy 5-axis machining, Intelligent Kinematic Compensation function is recommended. This function minimizes error in complex 5-axis machining applications by maintaining tip of the tool in correct position in respect to the workpiece. In order to properly utilize this function, following four optional items are required.



#### Recommended optional items

**1. Software**



FANUC NC: DCP-i (Developed by DOOSAN)



Heidenhain NC: Kinematic opt

**2. Receiver**



**3. Touch Probe**



**4. Datum ball**



Basic Information

Basic Structure  
Cutting  
Performance

Detailed Information

Options  
Capacity Diagram  
Specifications

Customer Support Service

User convenience has been significantly enhanced with a new operation panel.

User-Friendly Operation Panel

Large 15inch screen and user-friendly operating function ensure convenient and efficient operation.



Large 15inch screen display

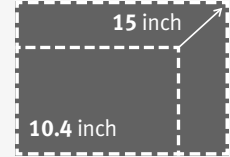

Design optimized for customers' needs based on extensive know-how

<b>Designed for user convenience</b>	Convenient and intuitive UI Optimized button size High-visibility lamps Long lifecycle buttons Partitioned to prevent operator error
<b>Convenient option buttons</b>	Detachable buttons Spare I/O signal ports for optional devices
<b>Customized functionality</b>	Customer-specific function switches Available for auxiliary panel design

Easy Operation Package

Setting up of tools, work pieces and programs, as well as troubleshooting for abnormal condition of main parts, is designed to minimize waiting time, maximize operational efficiency, and enhance operator convenience.



**Adaptive Feed Control (AFC)**  
Function to control feedrate so that the cutting can be carried out at a constant load (To adapt to the spindle load set up with constant load feedrate control function)



**Tool Management**  
Function to manage tool information  
[Tool information]  
- Tool No.  
- Tool condition : normal, large diameter, worn/damaged, used for the first time, manual  
- Tool name



**Tool Load Monitor**  
Function to automatically monitor tool load (Different loads can be set for one tool according to M700 ~ M704)



**Pattern Cycle** (Engraving function : **option**)  
Function to create frequently-used cutting programs automatically  
- Pattern Cycle: creates a program for a pre-defined shape  
- Engraving: creates a program for cutting a shape described with characters (option)



**Work Offset Setting**  
Function to configure various work offset settings



**Alarm Guidance**  
Function to show detailed info on frequently triggered alarms and recommended actions



**Sensor Status Monitor**  
Function to view sensor conditions of the machine



**ATC Recovery**  
Function to view detailed info with recommended actions and to perform step-by-step operation manually (when an alarm is triggered during an ATC operation)

## HEIDENHAIN iTNC530

### Superior Hardware Specifications

15" LCD and capacious 21GB memory



15" LCD



Description	HEIDENHAINITNC530	Remarks
Screen size	15" STD	-
Storage memory	21GB STD	-
Interference prevention system	Optional	-
Kinematic OPT.	Optional	Measuring device not included
Look-ahead block	1024 blocks	-
3D line graphics	Std.	-

## SIEMENS 840Dsl

### Providing a perfect 5-axis machining environment

15-inch LCD and SINUMERIK Mdynamics 5-axis machining package (standard)



Large 15inch screen display



**Mdynamics**  
5-axis machining package

#### Main features

- Advanced Surface
- HMI user memory on CF-Card (min. 1GB program memory)
- Automatic Measuring cycles functions
- 3D simulation functions
- Real-time simulation functions
- ShopMill (an interactive machining support function)

# Spindle

## Basic Information

- Basic Structure
- Cutting
- Performance

## Detailed Information

- Options
- Capacity Diagram
- Specifications

## Customer Support Service

### Spindle Power – Torque Curve

#### FANUC 31i-5

Max. spindle speed  
 - 12000 r/min  
 - 20000 r/min **option**

Spindle motor power (30min/cont.)  
 - 22/18.5 kW (29.5/24.8 Hp)  
 - 12000 & 20000 r/min common

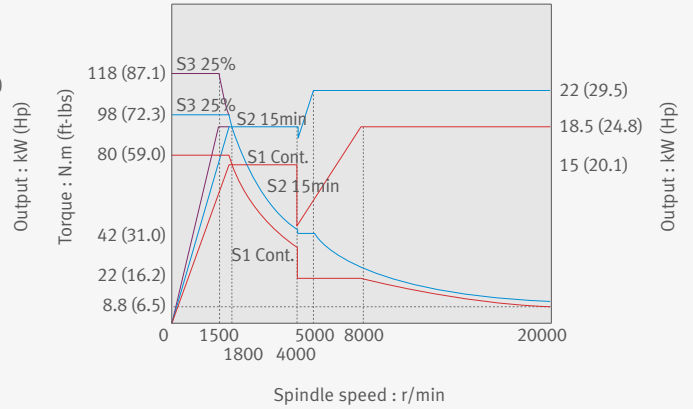
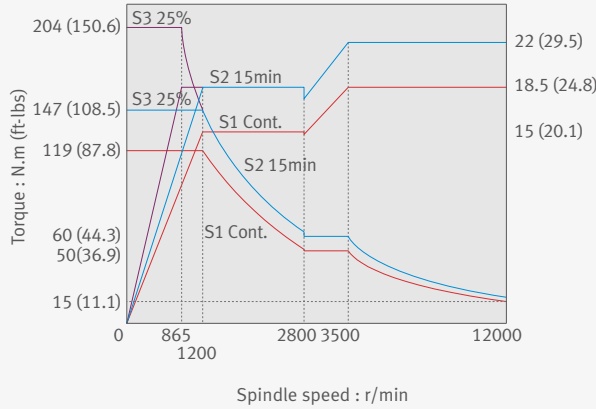

#### HEIDENHAIN iTNC530 **option**

Max. spindle speed  
 - 12000 r/min  
 - 20000 r/min **option**

Spindle motor power (30min/cont.)  
 - 23.5/18 kW (31.5/24.2 Hp) : 12000 r/min  
 - 28/24 kW (37.6/32.2 Hp) : 20000 r/min

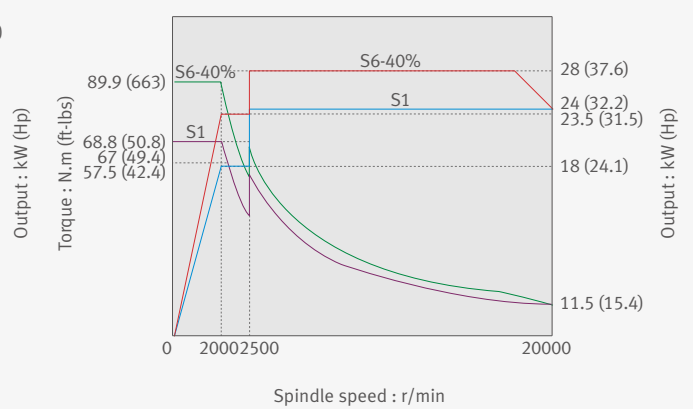
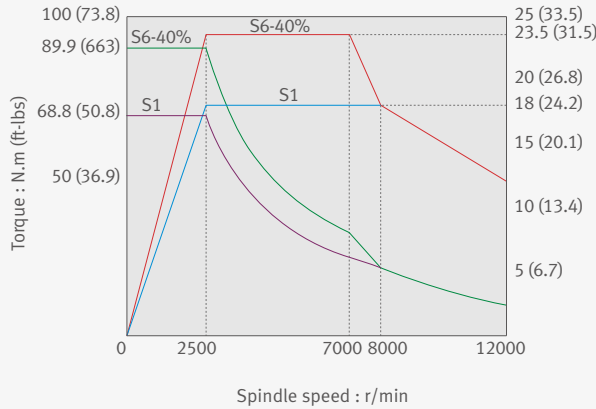

#### SIEMENS 840Dsl **option**

Max. spindle speed : 12000 r/min

Spindle motor power(30min/cont.)  
 - 30/24 kW (40.3/32.2 Hp)

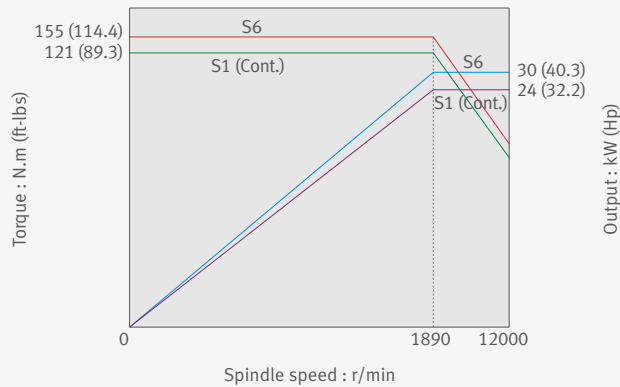

## External Dimensions

### VC 630/5AX (Standard type)

Unit : mm (inch)

Top view

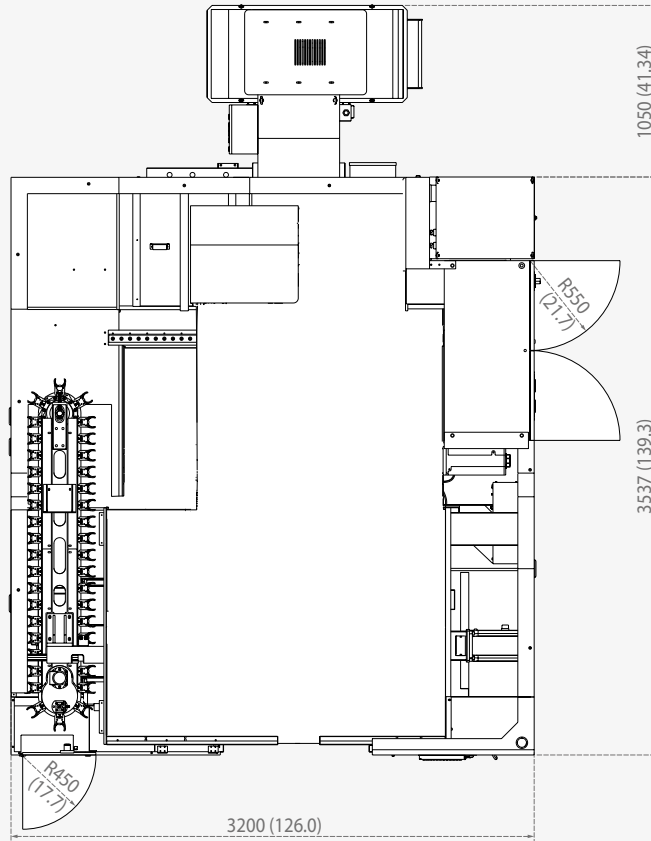

Front view

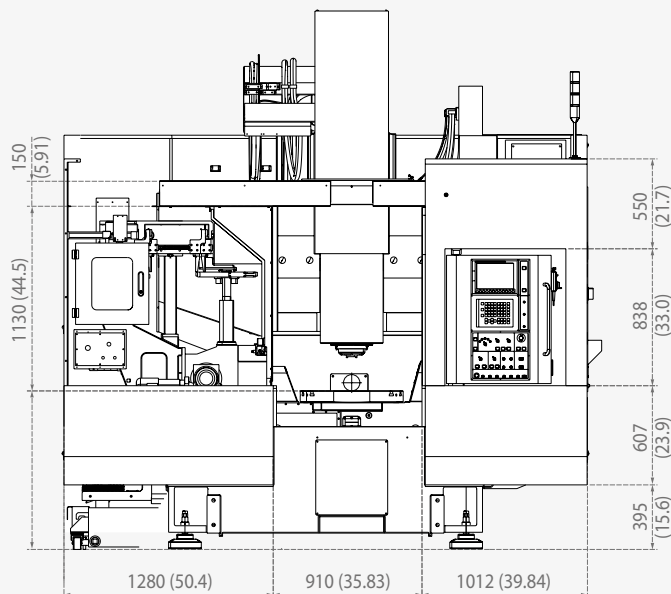

## External Dimensions

### Basic Information

- Basic Structure
- Cutting
- Performance

### Detailed Information

- Options
- Capacity Diagram
- Specifications

### Customer Support Service

## VC 630/5AX (APC type)

Unit : mm (inch)

Top view

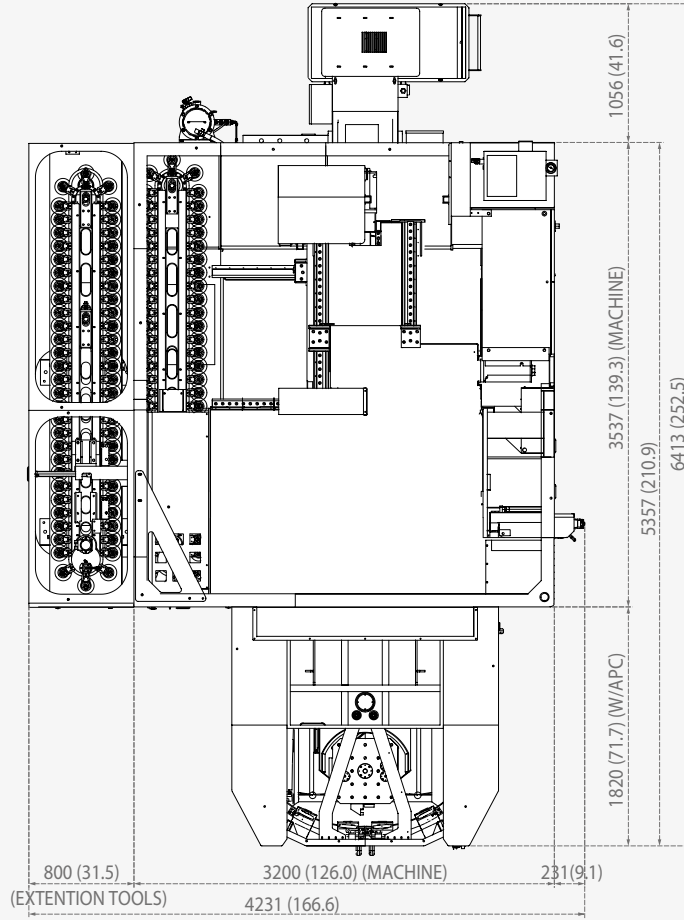

Front view

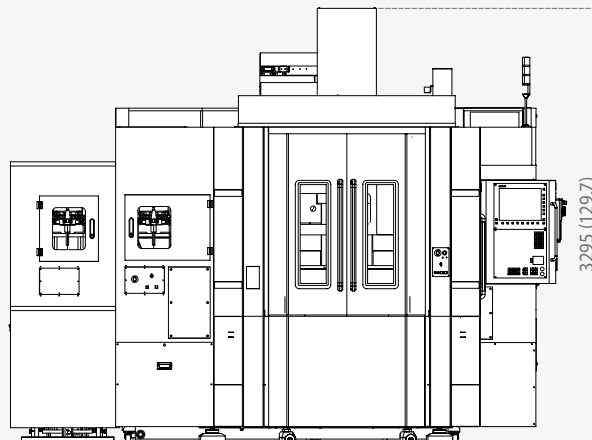



## Table dimension / Tool shank

### Table dimension

Standard type

Unit : mm (inch)

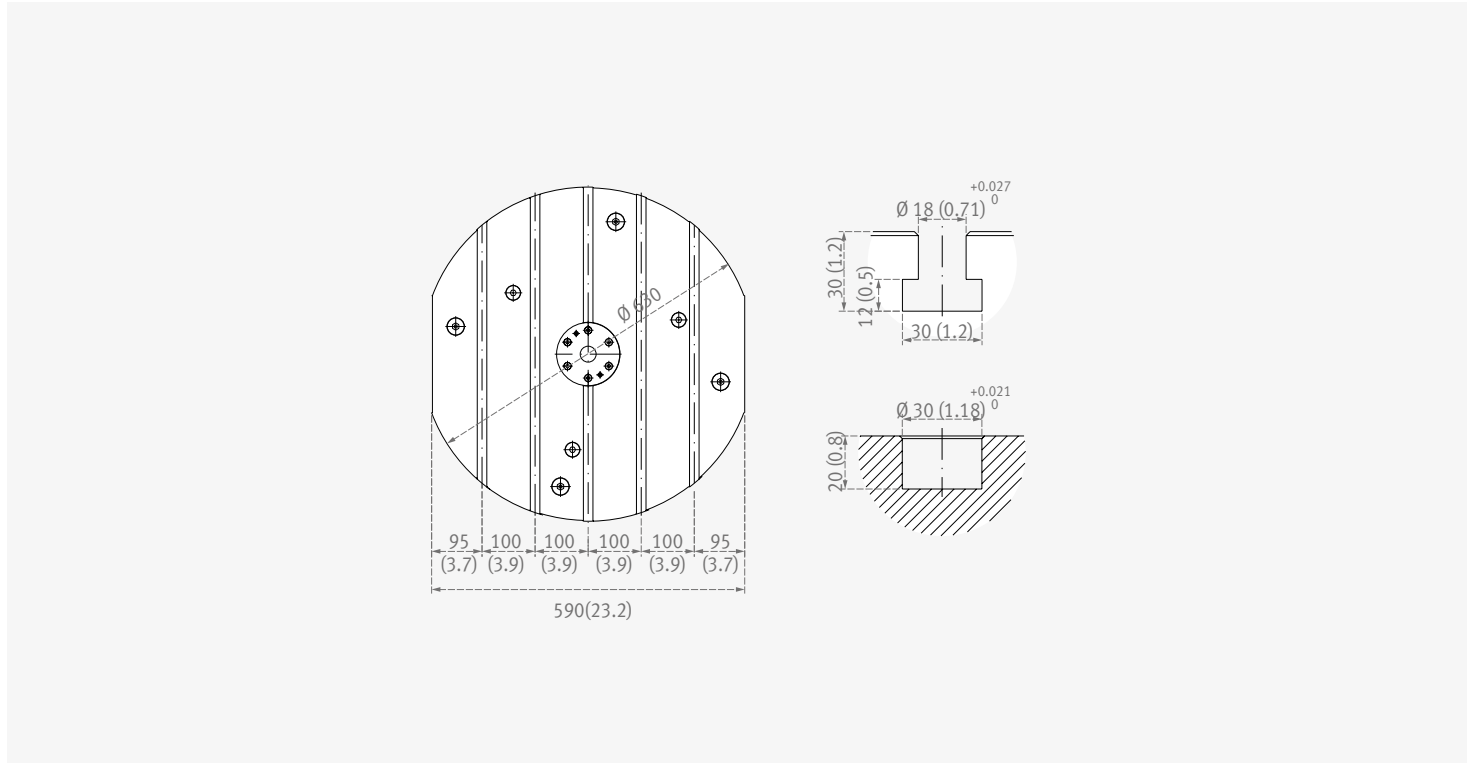

APC type

Unit : mm (inch)

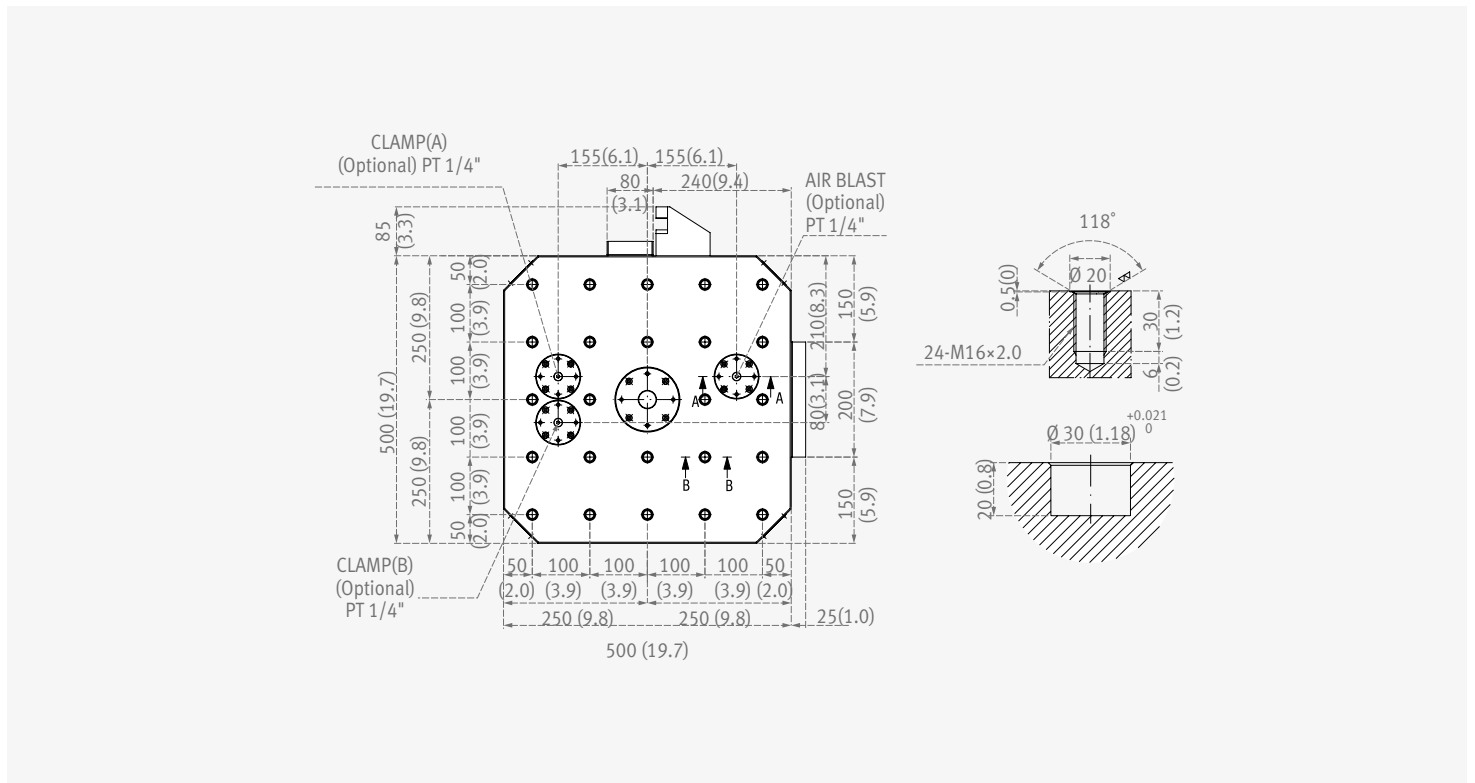



## Machine Specifications



Description		Unit	VC 630/5AX	VC 630/5AX with APC
Travels	X-axis	mm (inch)	650 (25.6)	
	Y-axis	mm (inch)	765 (30.1)	
	Z-axis	mm (inch)	520 (20.5)	
	A-axis	deg.	150 (+30~ -120)	
	C-axis	deg.	360	
	Distance from spindle nose to table top	mm (inch)	210 ~ 730 (8.3~28.7)	160 ~ 680 (6.3~26.8)
	Distance from spindle center to column guideway	mm (inch)	220 (8.7)	
Feedrate	Rapid traverse rate (X / Y / Z)	m/min (ipm)	40 / 40 / 36 (1574.8 / 1574.8 / 1417.3)	
	Rapid traverse rate (A / C)	r/min	20 / 30	
	Cutting feedrate (X / Y / Z)	mm/min (ipm)	18000 (708.7)	
	Cutting feedrate (A / C)	deg/min	7200	
Table	Table size	mm (inch)	ø 630 (24.8)	500 x 500 (19.7 x 19.7)
	Table loading capacity	kg (lb)	500 (1102.3)	
	Max. workpiece swing diameter x height	mm (inch)	ø 730 x 500 (28.7 x 19.7)	ø 730 x 450 (28.7 x 17.7)
	Minimum table indexing angle	-	0.001	
Spindle	Max. spindle speed	r/min	12000 {20000}	
	Spindle taper	-	ISO#40 7 / 24 Taper	
	Max. spindle torque	N.m (ft-lb)	204 (150.6) (25% ED)	
Automatic tool changer	Type of tool shank	-	MAS403 BT40	
	Tool storage capacity	ea	40 {60 / 81 / 101 / 121}	
	Max. tool diameter	mm (inch)	ø 80 (59.0)	
	Max. tool diameter without adjacent tools	mm (inch)	ø 125 (92.3)	
	Max. tool length	mm (inch)	300 (221.4)	
	Max. tool weight	kg (lb)	8 (17.6)	
	Method of tool selection	-	Fixed address	
	Tool change time (tool-to-tool)	s	1.0	
Automatic pallet changer	Number of pallet	ea	-	2
	Type	-	-	Rotary shuttle
	Pallet change time	s	-	30
Motor	Spindle motor power	kW (Hp)	FANUC 31i-5 : 22/18.5 (29.5/24.8 Hp) {HEIDENHAIN iTNC 530 : 23.5/18(31.5/24.2 Hp), 12000 r/min / 28/24(37.6/32.2 Hp) : 20000 r/min} {SIEMENS 840 Dsl : 30/24(40.3/32.2 Hp)}	
Power source	Electric power supply	kVA	53.3	
	Compressed air supply	MPa	0.54	
Tank capacity	Coolant tank capacity	L (gallon)	360 (95.1)	
	Lubrication tank capacity	L (gallon)	1.32 (0.4)	
Machine Dimensions	Machine dimension (L x W x H)	mm (inch)	3537(4587 : with chip conveyor) x 3200 x 3295 (139.3(180.6 : with chip conveyor) x 126 x 129.7)	5357(with chip conveyor : 6413) x 4231 x 3295 (210.9(with chip conveyor : 252.5) x 166.6 x 129.7)
	Machine weight	kg (lb)	12500 (27557.4)	16000 (35273.4)
NC System			FANUC 31i-5 {DOOSAN FANUC i / HEIDENHAIN iTNC 530 / SIEMENS 840 Dsl}	

\* { } : Option

FANUC

## Basic Information

Basic Structure  
Cutting  
Performance

## Detailed Information

Options  
Capacity Diagram  
Specifications

## Customer Support Service

NO.	Description	Spec.	DOOSAN-FANUC i	FANUC 31i-5
1	Controlled axes	3 (X, Y, Z)	X, Y, Z, B, (5)	X, Y, Z, B, (5)
2	Additional controlled axes	5 axes in total	●	●
3	Least command increment	0.001 mm / 0.0001"	●	●
4	Least input increment	0.001 mm / 0.0001"	●	●
5	Interpolation type pitch error compensation		○	○
6	2nd reference point return	G30	●	●
7	3rd / 4th reference return		●	●
8	Inverse time feed		●	○
9	Cylindrical interpolation	G07.1	●	○
10	Helical interpolation B	Only Fanuc 30i	-	○
11	Smooth interpolation		-	○
12	NURBS interpolation		-	○
13	Involute interpolation		-	○
14	Helical involute interpolation		-	○
15	Bell-type acceleration/deceleration before look ahead interpolation		●	●
16	Smooth backlash compensation		○	●
17	Automatic corner override	G62	●	○
18	Manual handle feed	Max. 3unit	1 unit	1 unit
19	Manual handle feed rate	x1, x10, x100 (per pulse)	●	●
20	Handle interruption		●	○
21	Manual handle retrace		○	○
22	Manual handle feed 2/3 unit		-	○
23	Nano smoothing	AI contour control II is required.	○	●
24	AI APC	20 BLOCK	X	X
25	AICC I	30 BLOCK	X	X
26	AICC I	40 BLOCK	X	X
27	AICC II	200 BLOCK	●	●
28	AICC II	400 BLOCK	-	○
29	High-speed processing	600 BLOCK	-	○
30	Look-ahead blocks expansion	1000 BLOCK	-	○
31	DSQ I	AICC II (200block) + Machining condition selection function	-	●
32	DSQ II	AICC II (200block) + Machining condition selection function + Data server (1GB)	-	○
33	DSQ III	AICC II with high speed processing (600block) + Machining condition selection function + Data server(1GB)	-	○
34	SPINDLE & M-CODE FUNCTION	M- code function	●	●
35		Retraction for rigid tapping	●	●
36		Rigid tapping	G84, G74	●
37		Number of tool offsets	64 ea	64 ea
38		Number of tool offsets	99 ea	○
39		Number of tool offsets	200 ea	○
40		Number of tool offsets	400 ea	400 ea
41		Number of tool offsets	499 / 999 / 2000 ea	○
42		Tool nose radius compensation	G40, G41, G42	●
43		Tool length compensation	G43, G44, G49	●
44		Tool life management	●	●
45		Addition of tool pairs for tool life management	●	○
46		Tool offset	G45 - G48	○

## NC Unit Specifications

● Standard ○ Optional X N/A

# FANUC

NO.	Description	Spec.	DOOSAN-FANUC i	FANUC 31i-5	
47	Custom macro		●	●	
48	Macro executor		●	●	
49	Extended part program editing		●	●	
50	Part program storage	256KB (640m)	-	640m	
51	Part program storage	512KB (1,280m)	1280m	○	
52	Part program storage	1MB (2,560m)	-	○	
53	Part program storage	2MB (5,120m)	○	○	
54	Part program storage	4MB (1,0240m)	-	○	
55	Part program storage	8MB (2,0480m)	-	○	
56	PROGRAMMING & EDITING FUNCTION	Inch/metric conversion	G20 / G21	●	●
57		Number of Registered programs	400 ea	400 ea	-
58		Number of Registered programs	500 ea	-	500 ea
59		Number of Registered programs	1000 ea	-	○
60		Number of Registered programs	4000 ea	-	○
61		Optional block skip	9 BLOCK	●	○
62		Optional stop	M01	●	●
63		Program file name	32 characters	-	●
64		Program number	O4-digits	●	-
65		Playback function		●	○
66		Addition of workpiece coordinate system	G54.1 P1 - 48 (48 pairs)	48 pairs	48 pairs
67		Addition of workpiece coordinate system	G54.1 P1 - 300 (300 pairs)	-	○
68		Embedded Ethernet		●	●
69		Graphic display	Tool path drawing	●	●
70		Loadmeter display		●	●
71		Memory card interface		●	●
72		USB memory interface	Only Data Read & Write	●	●
73		Operation history display		●	●
74		DNC operation with memory card		●	●
75		Optional angle chamfering / corner R		●	●
76		Run hour and part number display		●	●
77		High speed skip function		●	○
78		Polar coordinate command	G15 / G16	●	○
79		Polar coordinate interpolation	G12.1 / G13.1	-	○
80		Programmable mirror image	G50.1 / G51.1	●	○
81	OTHERS FUNCTIONS (Operation, setting & Display, etc)	Scaling	G50, G51	●	○
82		Single direction positioning	G60	●	○
83		Pattern data input		●	○
84		Jerk control	AI contour control II is required.	○	○
85		Fast Data server with 1GB PCMCIA card		○	○
86		Fast Ethernet		○	○
87		3-dimensional coordinate conversion		●	●
88		3-dimensional tool compensation		-	○
89		Figure copying	G72.1, G72.2	-	○
90		Machining time stamp function		-	○
91		EZ Guide I with 10.4" Color TFT	Doosan infracore Conversational Programming Solution - When the EZ Guide i is used, the Dynamic graphic display cannot application	○	○
92		Dynamic graphic display (with 10.4" Color TFT LCD)	- Machining profile drawing. - When the EZ Guide i is used, the Dynamic graphic display cannot application	○	○

## HEIDENHAIN

## Basic Information

Basic Structure  
Cutting  
Performance

## Detailed Information

Options  
Capacity Diagram  
Specifications

## Customer Support Service

No.	Description	Spec.	iTNC 530
1	Axes	Controlled axes	5 axes
2			Max. 18 axes in total
3		Least command increment	0.0001 mm (0.0001 inch), 0.0001°
4		Least input increment	0.0001 mm (0.0001 inch), 0.0001°
5		Maximum commandable value	±99999.999mm (±3937 inch)
6		Axis feedback control	Double-speed control loops for high-frequency spindles and torque/linear motors
7		MDI / DISPLAY unit	15.1 inch TFT color flat panel
8			19 inch TFT color flat panel
9		Program memory for NC programs	SSDR
10		Block processing time	
11		Cycle time for path interpolation	CC 61xx
12		Encoders	Absolute encoders
13	Commissioning and diagnostics	Data interfaces	Ethernet interface
14			USB interface (USB 2.0)
15	Machine functions	Look-ahead	Intelligent path control by calculating the path speed ahead of time (max. 1024 blocks.)
16		HSC filters	
17		Switching the traverse ranges	
18	User functions	Program input	According to ISO
19			With smarT.NC
20		Position entry	Nominal positions for lines and arcs in Cartesian coordinates
21			Incremental or absolute dimensions
22			Display and entry in mm or inches
23			Display of the handwheel path during machining with handwheel superimpositioning
24			Paraxial positioning blocks
25		Tool compensation	In the working plane and tool length
26			Radius-compensated contour lookahead for up to 99 blocks (M120)
27			Three-dimensional tool radius compensation
28		Tool table	Central storage of tool data
29			Multiple tool tables with any number of tools
30		Cutting-data table	Calculation of spindle speed and feed rate based on stored tables
31		Constant contouring speed	relative to the path of the tool center or to the tool's cutting edge
32		Parallel operation	Creation of a program while another program is being run
33		Tilting the working plane with Cycle 19	
34		Tilting the working plane with the PLANE function	
35		Manual traverse in tool-axis direction	after interruption of program run
36		Function TCPM	Retaining the position of tool tip when positioning tilting axes
37		Rotary table machining	Programming of cylindrical contours as if in two axes
38			Feed rate in distance per minute
39		FK free contour programming	for workpieces not dimensioned for NC programming
40		Program jumps	Subprograms and program section repeats
41			Calling any program as a subprogram
42		Program verification graphics	Plan view, view in three planes, 3-D view
43		Programming graphics	3-D line graphics
44		Program-run graphics	(plan view, view in three planes, 3-D view)

# NC Unit Specifications

● Standard ○ Optional X N/A

## HEIDENHAIN

No.	Description	Spec.	ITNC 530	
45	Datum tables	Saving of workpiece-specific datums	●	
46	Preset table	Saving of reference points	●	
47	Freely definable table	after interruption of program run	●	
48	Returning to the contour	With mid-program startup	●	
49		After program interruption (with the GOTO key)	●	
50	Autostart		●	
51	Actual position capture		●	
52	Enhanced file management		●	
53	Context-sensitive help for error messages		●	
54	TNCguide	Browser-based, context-sensitive helpsystem	●	
55	Calculator		●	
56	Entry of text and special characters		●	
57	Comment blocks in NC program		●	
58	"Save As" function		●	
59	Structure blocks in NC program		●	
60	Entry of feed rates	FU (feed per revolution)	●	
61		FZ (tooth feed per revolution)	●	
62		FT (time in seconds for path)	●	
63		FMAXT (only for rapid traverse pot: time in seconds for path)	●	
64	Dynamic collision monitoring (DCM)		○	
65	Fixture monitoring		○	
66	Processing DXF data		○	
67	Global program settings (GS)		○	
68	Adaptive feed control (AFC)		○	
69	KinematicsOpt	Automatic measurement and optimization of machine kinematics	○	
70	KinematicsComp	Three-dimensional compensation	○	
71	3D-ToolComp	Dynamic 3-D tool radius compensation	○	
72	Fixed cycles	Working plane	Cycle 19	●
73		Cylinder surface	Cycle 27	●
74		Cylinder surface slot milling	Cycle 28	●
75		Cylinder surface ridge milling	Cycle 29	●
76	Cycles for automatic workpiece inspection	Calibrate TS		●
77		Calibrate TS length		●
78		Measure axis shift		●
79		Save kinematics		○
80		Measure kinematics		○
81		Preset compensation		○
82	Options	Software option 1		
83		- Rotary table machining	Programming of cylindrical contours as if in two axes	
84			Feed rate in mm/min	●
85		- Coordinate transformation	Tilting the working plane, PLANE function	
86		- Interpolation	Circular in 3 axes with tilted working plane	
87		Software option 2		
88		- 3-D machining	3-D tool compensation through surface normal vectors	
89			Tool center point management (TCPM)	
90			Keeping the tool normal to the contour	
91			Tool radius compensation normal to the tool direction	●
92		- Interpolation	Line in 5 axes (subject to export permit)	
93	Spline: execution of splines (3rd degree polynomial)			

## Basic Information

Basic Structure  
Cutting  
Performance

## Detailed Information

Options  
Capacity Diagram  
Specifications

## Customer Support Service

SIEMENS

NO.		Description	Spec.	S840Dsl	
1	AXES CONTROL	Controlled axes	3 axes	X	
2			4 axes	X	
3			5 axes	X, Y, Z, C, A	
4		Simultaneously controlled axes	Positioning(G00)/Linear interpolation(G01) : 3 axes Circular interpolation(G02, G03) : 2 axes	X	
5			Positioning(G00)/Linear interpolation(G01) : 4 axes Circular interpolation(G02, G03) : 2 axes	X	
6			Least command increment	0.001mm (0.0001 inch)	●
7			Least input increment	0.001mm (0.0001 inch)	X
8			Maximum commandable value	±99999.999mm (±3937 inch)	●
9	INTERPOLATION & FEED FUNCTIONS	Reference point return		●	
10		Inverse time feedrate	G93	○	
11		Spline interpolation (A, B and C splines)		●	
12	SPINDLE FUNCTIONS	Retraction for rigid tapping		●	
13		Rigid tapping		●	
14	TOOL FUNCTIONS	<b>Tool radius compensations in plane</b>			
15		• With approach and retract strategies		●	
16		• With transition circle / ellipse on outer edges		●	
17		Number of tools / cutting edges in tool list	256 / 512	X	
18		Tool length compensation		●	
19		Tool offset selection via T and D numbers		●	
20		Replacement tools for tool management		●	
21	Monitoring of tool life and workpiece count		●		
22	PROGRAMMING & EDITING FUNCTIONS	Main program call from main program and subroutine		●	
23		Subroutine levels and interrupt routines, max.		16 / 2	
24		Number of subroutine passes ≤ 9999		●	
25		Number of levels for skip blocks 1		●	
26		Number of levels for skip blocks 8		○	
27		Polar coordinates		●	
28		<b>Auxiliary function output</b>			
29		• Via M word, max. programmable value range: INT 231-1		●	
30		• Via H word, max. range: REAL ± 3.4028 ex 38/ INT -231 ... 231-1		●	
31		<b>High-level CNC language with</b>			
32		• User variables, configurable		●	
33		• Read/write system variables		●	
34		• Indirect programming		●	
35		• Program jumps and branches		●	
36		• Arithmetic and trigonometric functions		●	
37		• Compare operations and logic combinations		●	
38		• Macro techniques		●	
39	• Control structures IF-ELSE-ENDIF		●		
40	• Control structures WHILE, FOR, REPEAT, LOOP		●		
41	• STRING functions		●		
42	<b>Program functions</b>				
43	• Dynamic preprocessing memory FIFO		●		
44	• Look ahead number of blocks		150		
45	• Frame concept		●		
46	• Inclined-surface machining with swivel cycle		●		
47	Online ISO dialect interpreter		●		



## NC Unit Specifications

● Standard ○ Optional X N/A

### SIEMENS

NO.	Description	Spec.	S840Dsl
48	<b>Program / workpiece management</b>		
49	• Parts programs on NCU, max. number		1000
50	• Workpieces on NCU, max. number		250
51	• On additional plug-in CF card		●
52	• On USB storage medium (e.g. disk drive, USB stick)		●
53	• On network drive		●
54	Basic frames, max. number		16
55	Settable offsets, max. number		100
56	<b>Program editor</b>		
57	PROGRAMMING & EDITING FUNCTIONS • Programming support for cycles program (Program Guide)		●
58	• CNC editor with editing functions: Marking, copying, deleting		●
59	• Programming graphics / free contour input (contour calculator)		●
60	Technology cycles for drilling / milling		●
61	Pocket milling free contour and islands stock removal cycle		●
62	Residual material detection		●
63	Access protection for cycles		●
64	Programming support can be extended, e.g. customer cycles		●
65	2D simulation		●
66	3D simulation, finished part		●
67	Simultaneous recording		●
68	<b>JOG</b>		
69	• Handwheel selection		●
70	• Switchover: inch / metric		●
71	<b>Automatic</b>		
72	• Execution from USB or CF card interface on operator panel front		●
73	• Execution from network drive		●
74	• DRF offset		●
75	• Block search with / without calculation		●
76	<b>Preset</b>		
77	• Set actual value		●
78	10.4" color display		X
79	15.0" color display		●
80	Plain text display of user variables		●
81	OTHERS FUNCTIONS (Operation, setting & Display, etc) <b>Operating software languages</b>		
82	• Ch_S,Ch_T, En, Fr, Gr, It, Kr, Pt, Sp		●
83	• Additional languages, use of language extensions		●
84	Working area limitation		●
85	Limit switch monitoring		●
86	Software and hardware limit switches		●
87	<b>Remote Control System (RCS) remote diagnostics</b>		
88	• RCS Host remote diagnostics function		○
89	• RCS Commander (viewer function)		●
90	Integrated service planner for the monitoring of service intervals		●
91	Automatic measuring cycles		●
92	Easy Extend		X
93	TRANSMIT / cylinder surface transformation		●
94	Contour handwheel		●
95	Integrate screens in SINUMERIK Operate with SINUMERIK Integrate Run MyScreens		●
96	Cross-mode actions (ASUPs and synchronized actions in all operating modes)		●

Product Overview

Basic Information

Basic Structure  
Cutting  
Performance

Detailed  
Information

Options  
Capacity Diagram  
Specifications

Customer Support  
Service

# Responding to Customers Anytime, Anywhere

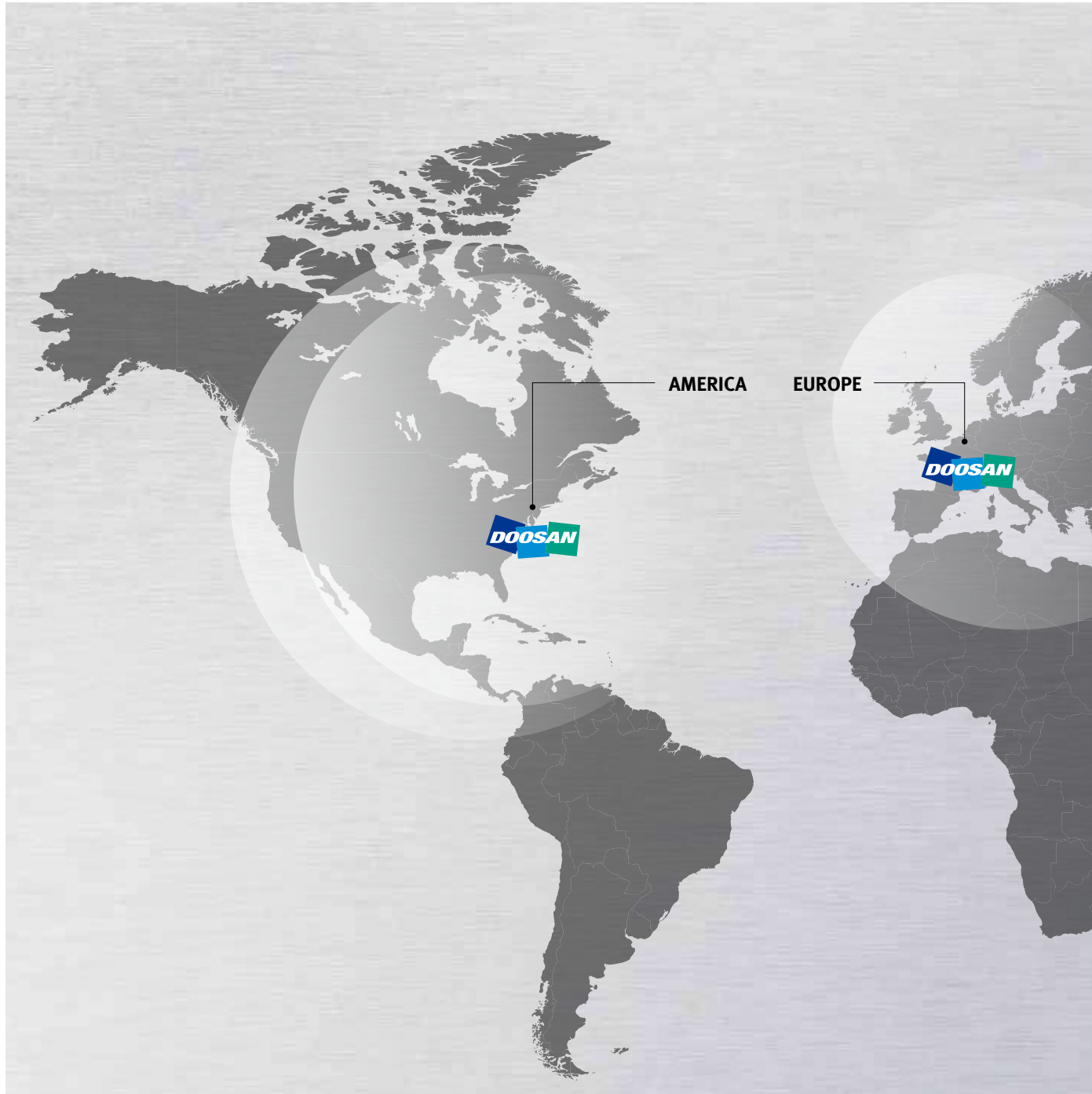

## Global Service Support Network

Corporations

5

Dealer Networks

122

Technical Centers

18

Factories

3

Technical Center: Sales Support, Service Support, Parts Support

## Doosan Machine Tools' Global Network, Responding to Customer's Needs nearby, Anytime, Anywhere

Doosan machine tools provides a system-based professional support service before and after the machine tool sale by responding quickly and efficiently to customers' demands. By supplying spare parts, product training, field service and technical support, we can provide top class support to our customers around the world.

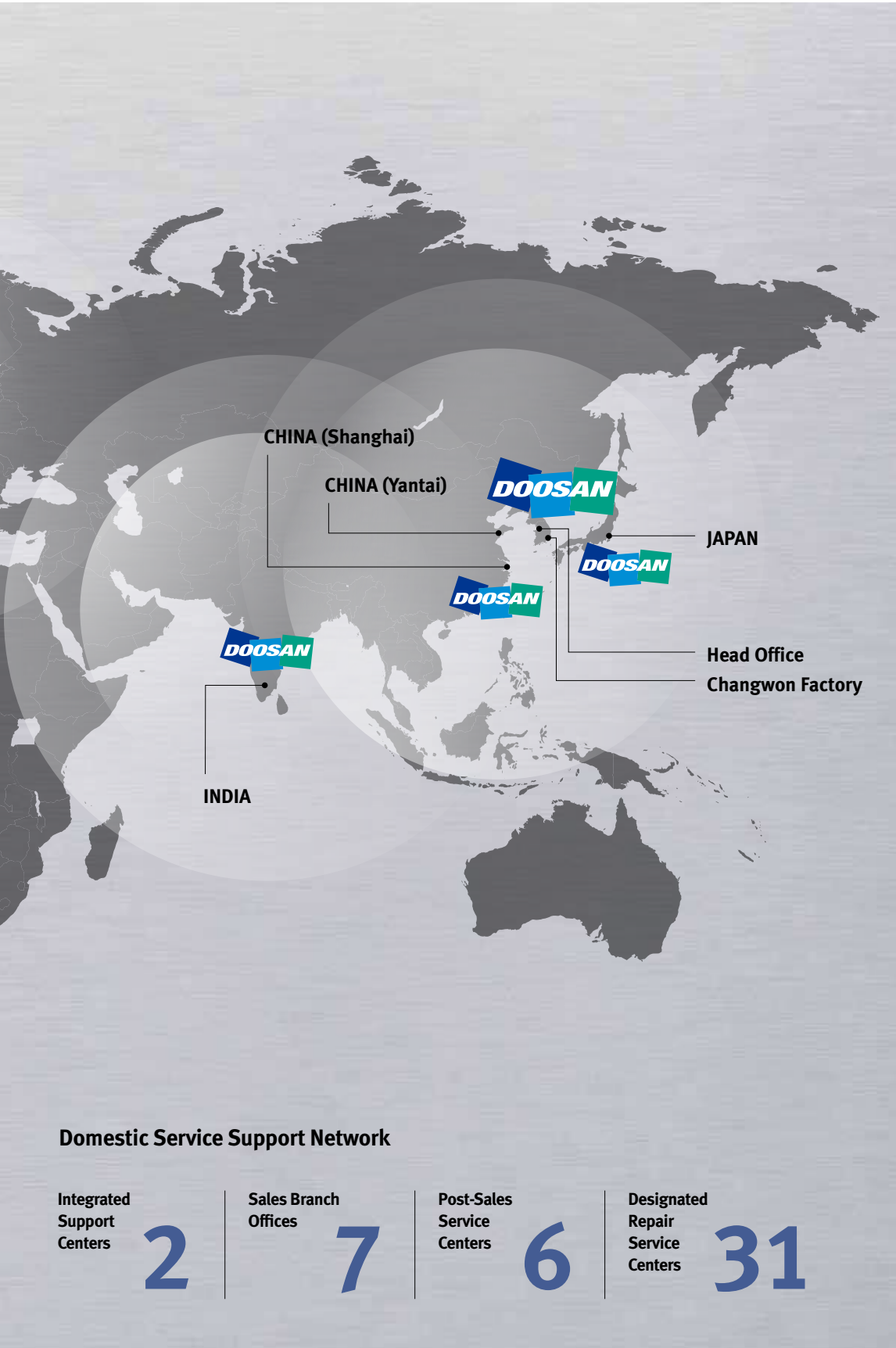

### Customer Support Service

We help customers to achieve success by providing a variety of professional services from pre-sales consultancy to post-sales support.

### Supplying Parts



- Supplying a wide range of original Doosan spare parts
- Parts repair service

### Field Services



- On site service
- Machine installation and testing
- Scheduled preventive maintenance
- Machine repair

### Technical Support



- Supports machining methods and technology
- Responds to technical queries
- Provides technical consultancy

### Training



- Programming / machine setup and operation
- Electrical and mechanical maintenance
- Applications engineering

## Major Specifications

### VC 630/5AX



Specification	UNIT	VC 630/5AX	VC 630/5AX with APC
Max. spindle speed	r/min	12000	
Spindle motor power	kW (Hp)	FANUC : 22 / 18.5 (29.5 / 24.8)	
Tool shank	Taper	ISO#40 7/24	
Travels (X, Y, Z)	mm (inch)	650 / 765 / 520 (25.6 / 30.1 / 20.5)	
Number of tools	ea	40	
Table size	mm (inch)	Ø630 (Ø23.6)	500 x 500 (19.7 x 19.7)
Travels (A, C)	deg	A-axis : 150 , C-axis : 360	
NC system	-	FANUC 31i-5	



## Doosan Machine Tools

<http://www.doosanmachinetools.com>

[www.facebook.com/doosanmachinetools](https://www.facebook.com/doosanmachinetools)

### Optimal Solutions for the Future

#### Head Office

Yeonkang Bldg., 6th FL., 270, Yeonji-dong,  
Jongno-gu, Seoul, Korea  
Tel +82-2-3670-5345 / 5362  
Fax +82-2-3670-5382

#### Doosan Machine Tools China

Room 101,201,301, Building 39 Xinzhuang Highway  
No.258 Songjiang District,China Shanghai(201612)  
Tel +86 21-5445-1155  
Fax +86 21-6405-1472

#### Doosan Machine Tools Japan

#2412, Mita Kokusai Bldg. 1-4-28 Mita,  
Minato-ku, Tokyo 108-0073, Japan  
Tel +81 3 5730 9013  
Fax +81 3 5730 9016

#### Doosan Machine Tools America

19A Chapin Rd., Pine Brook, NJ 07058, U.S.A.  
Tel +1-973-618-2500  
Fax +1-973-618-2501

#### Doosan Machine Tools Europe

Emdener Strasse 24, D-41540 Dormagen, Germany  
Tel +49-2133-5067-100  
Fax +49-2133-5067-111

#### Doosan Machine Tools India

106 / 10-11-12, Amruthahalli, Byatarayanapura,  
Bellary road, Bangalore-560 092, India  
Tel +91-80-4266-0122 / 121 / 100



\* For more details, please contact Doosan Machine Tools.

\* The specifications and information above-mentioned may be changed without prior notice.

\* Doosan Machine Tools Co., Ltd. is a subsidiary of MBK Partners. The trademark  DOOSAN is used under a licensing agreement with Doosan Corporation, the registered trademark holder.