

DOOSAN

**MACHINE
GREATNESS™**

DNM #50 II series

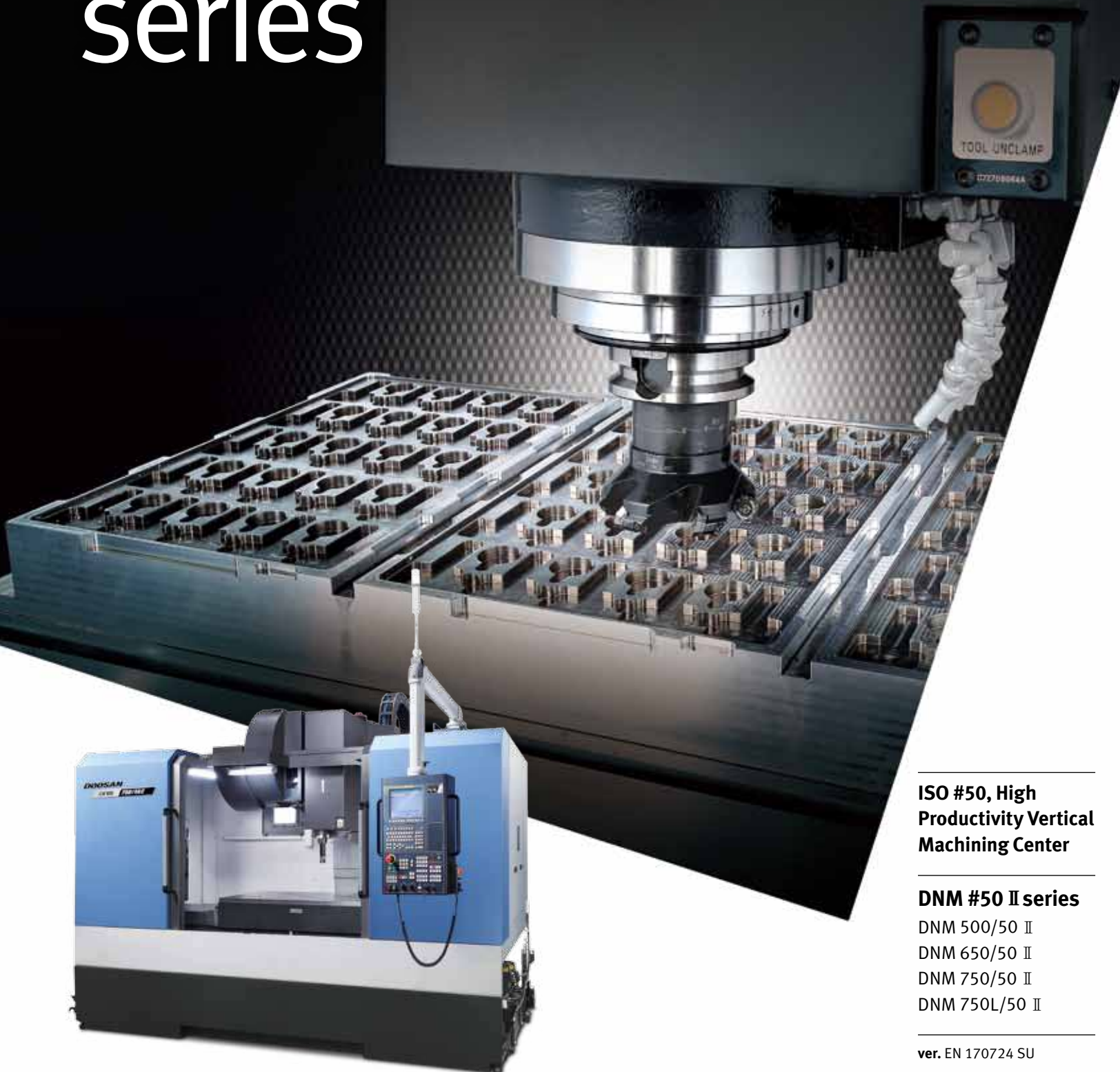

**ISO #50, High
Productivity Vertical
Machining Center**

DNM #50 II series

DNM 500/50 II

DNM 650/50 II

DNM 750/50 II

DNM 750L/50 II

ver. EN 170724 SU

Basic Information

Basic Structure
Cutting
Performance

Detailed Information

Options
Applications
Diagrams
Specifications

Customer Support Service



DNM #50 II series

Designed for high performance, the DNM50II series is equipped with direct coupled spindle, high rigidity column and roller guideways on all axes. In addition, the Easy Operation Panel (EOP) functions improve operator convenience.



DNM 650/50 II

Contents

02 Product Overview

Basic Information

04 Basic Structure

07 Cutting Performance

Detailed Information

08 Standard / Optional Specifications

10 Applications

12 Diagrams

16 Machine / CNC Specifications

18 Customer Support Service

Standard Direct-Coupled Spindle for Higher Productivity, high rigidity structure

- The direct coupled spindle reduces vibration and noise, thereby improving machining performance and environmental conditions.
- High rigidity column and Roller LM guide are adopted for heavy duty machining performance .

Easy operation of CNC system

- Easy operation for user's convenient machine operation.
- The EOP functions improve userfriendliness for operators.

Basic structure

The highly rigid column is adopted for heavy duty machining performance. This machining center offers workpiece capacity from 540 to 762 mm in the Y axis, enabling the user to handle a wider range of workpieces.

Basic Information

Basic Structure
Cutting
Performance

Detailed Information

Options
Applications
Diagrams
Specifications

Customer Support Service

Traver distance (X x Y x Z axis)

DNM 500/50 II

1020 x 540 x 510mm
(40.2 x 21.3 x 20.1 inch)

DNM 650/50 II

1270 x 670 x 625mm
(50.0 x 26.4 x 24.6 inch)

DNM 750/50 II

1630 x 762 x 650mm
(64.2 x 30.0 x 25.6 inch)

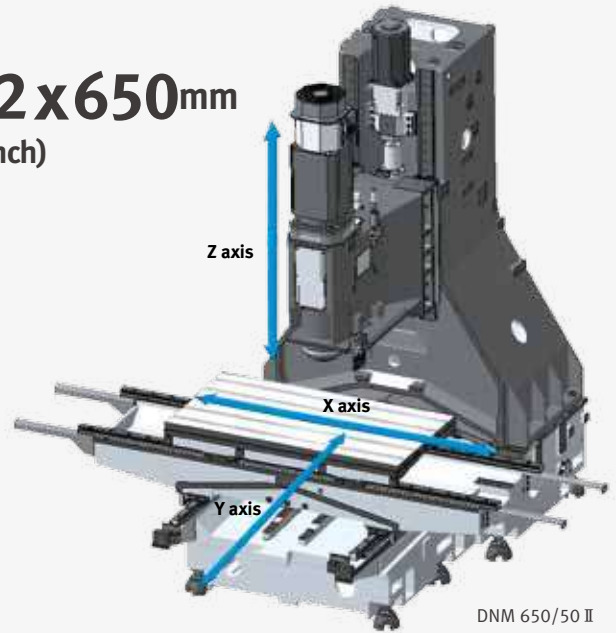

DNM 750L/50 II

2160 x 762 x 650mm
(85.0 x 30.0 x 25.6 inch)

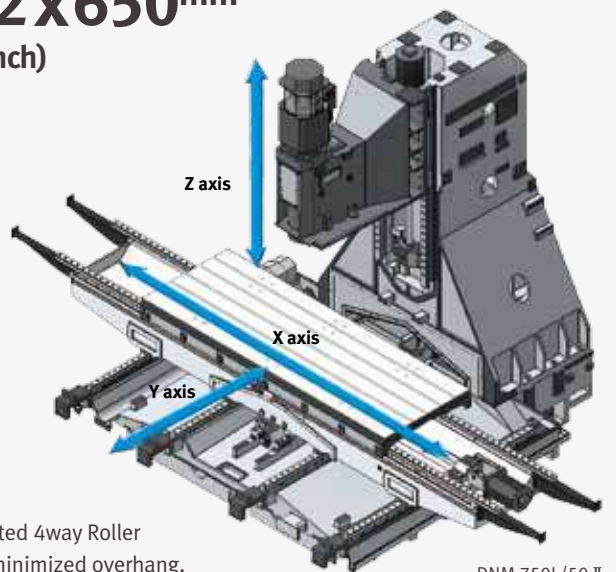

DNM 750L/50 II has adopted 4way Roller LM guide in the Y axis for minimized overhang.

Axis system

Roller LM guideways are adopted as standard on all axes to ease maintenance and improve rigidity.

Rapid traverse rate (X / Y / Z axis)

DNM 500/50 II, DNM 650/50 II

36 / 36 / 30 m/min
(1417.3 / 1417.3 / 1181.1 ipm)

DNM 750/50 II

30 / 30 / 24 m/min
(1181.1 / 1181.1 / 944.9 ipm)

DNM 750L/50 II

24 / 24 / 24 m/min
(944.9 / 944.9 / 944.9 ipm)



Roller LM guideway life is longer about twice than Ball LM guideway.

Table

DNM #50 series offers wide range cutting volume to meet a variety of workpiece.

Table size (A x B)

DNM 500/50 II

1200 x 540 mm
(47.2 x 21.3 inch)

DNM 650/50 II

1300 x 670 mm
(51.2 x 26.4 inch)

DNM 750/50 II

1630 x 760 mm
(64.2 x 29.9 inch)

DNM 750L/50 II

2160 x 760 mm
(85.0 x 29.9 inch)

Max. weight on Table

DNM 500/50 II

800kg
(1763.7 lb)

DNM 650/50 II

1000kg
(2204.6 lb)

DNM 750/50 II

1500kg
(3306.9 lb)

DNM 750L/50 II

1800kg
(3968.3 lb)

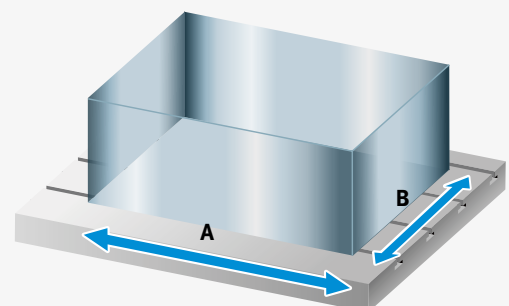

Basic Information

- Basic Structure
- Cutting
- Performance

Detailed Information

- Options
- Applications
- Diagrams
- Specifications

Customer Support Service

Spindle

The direct coupled spindle reduces vibration and noise, thereby improving the machines performance and environmental-friendliness. Dual contact spindle has been adopted as a standard to provide heavy duty machining performance.

Max. spindle speed

8000 r/min
10000 r/min option

Max. spindle motor power

22 kW (29.5 Hp)
26 kW (34.9 Hp) option

Max. spindle motor torque

353.2 N·m
 (260.7 ft-lbs)
165.5 N·m option
 (122.1 ft-lbs)

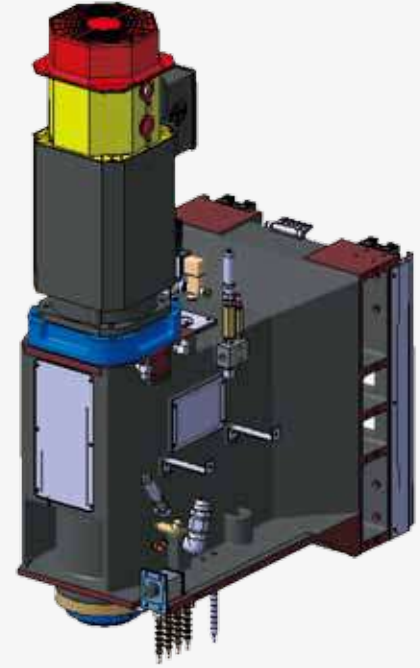

Direct coupled spindle of DNM 650/50 II

Tool change system

Higher productivity can be achieved with the CAM-type tool changer that supports faster tool changing.

Tool to Tool

2.5 sec

Chip to Chip*

5.5 sec

Tool storage capacity

24 ea

30 ea option
 (Except for DNM 500/50 II)



* The Chip-to-Chip time has been tested in accordance with Doosan's strict testing conditions, but may vary depending on the user's operating conditions



Cutting Performance

To provide best cutting performance by #50. Tool change time has been optimized to reduce non cutting time.

Machining performance

Result of cutting test on DNM 650/50 II (8000r/min, Direct, 22 / 11kW (29.5 / 14.8Hp))

Face mill (ø125 mm (ø4.9 inch)) Carbon steel (SM45C)

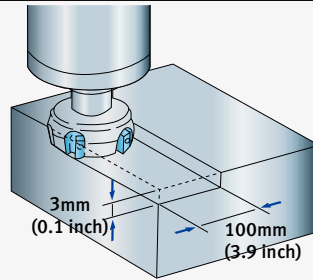

Chip removal rate (cm ³ /min(inch ³ /min))	Spindle speed (r/min)	Feedrate (mm/min (ipm))
480 (29.3)	500	1600 (63.0)

Face mill (ø125 mm (ø4.9 inch)) Carbon steel (SM45C)

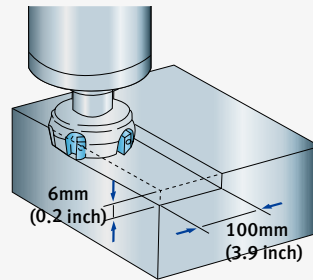

Chip removal rate (cm ³ /min(inch ³ /min))	Spindle speed (r/min)	Feedrate (mm/min (ipm))
356 (21.7)	500	594 (23.4)

U-Drill (ø70 mm (ø2.8 inch)) Carbon steel (SM45C)

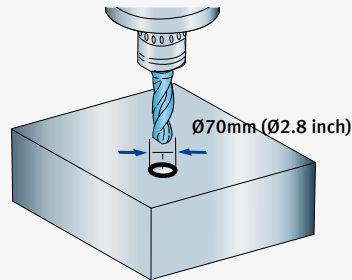

Chip removal rate (cm ³ /min(inch ³ /min))	Spindle speed (r/min)	Feedrate (mm/min (ipm))
385 (23.5)	500	100 (3.9)

Tap Carbon steel (SM45C)

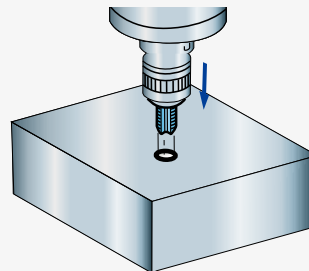

Tap size (mm)	Spindle speed (r/min)	Feedrate (mm/min (ipm))
M36 x P4.0	177	708 (27.9)

* The results, indicated in this catalogue are provides as example. They may not be obtained due to differences in cutting conditions and environmental conditions during measurement.



Basic Information

Basic Structure
Cutting
Performance

Various optional features are available to satisfy customers' specific machining applications.

Detailed Information

Options
Applications
Diagrams
Specifications

Customer Support Service

NO.	Description	Features		DNM	DNM	DNM	DNM	
				500/50 II	650/50 II	750/50 II	750L/50 II	
1	Spindle	8000 r/min	22/11 kW (29.5/14.8 Hp) (S3 25%/Cont.)	●	●	●	●	
2		10000 r/min	26/22 kW (34.9/29.5 Hp) (S3 40%/Cont.)	○	○	○	○	
3	Spindle cooling system	8000 r/min	22/11 kW (29.5/14.8 Hp)	●	●	●	●	
4		10000 r/min	26/22 kW (34.9/29.5 Hp)	●	●	●	●	
5	Magazine	Tool storage capacity	24 ea	●	●	●	●	
6			30 ea	X	○	○	○	
7	Tool shank type	BIG PLUS BT50		●	●	●	●	
8		BIG PLUS CAT50		○	○	○	○	
9		BIG PLUS DIN50		○	○	○	○	
10	Raised block	150mm (5.9 inch)		○	○	○	○	
11		200mm (7.9 inch)		○	○	○	○	
12		300mm (11.8 inch)		○	○	○	○	
13	FLOOD	0.15 Mpa (21.8 psi), 0.4 kW (0.5 Hp)		●	●	●	●	
14		0.7 MPa (101.5 psi), 1.8 kW (2.4 Hp)		○	○	○	○	
15	TSC	None		●	●	●	●	
16		2 MPa (290.0 psi), 1.5kW (2.0 Hp)		○	○	○	○	
17		2 MPa (290.0 psi), 4.0 kW (5.4 Hp)		○	○	○	○	
18		7 Mpa (1015.0 psi), 5.5 kW (7.4 Hp)		○	○	○	○	
19	SHOWER	0.1 MPa (14.5 psi), 1.1 kW (1.5 Hp)		○	○	○	○	
20	Oil skimmer	Belt type		○	○	○	○	
21	MQL			○	○	○	○	
22	Chip disposal	Chip pan		●	●	●	●	
23		Chip conveyor	Hinged type (Left/Right/Rear)		○	○	○	○
24			Magnetic scraper type (Left/Right/Rear)		○	○	○	○
25			Drum filter type (Rear)		○	○	○	○
26		Chip bucket		○	○	○	○	
27		Air blower		○	○	○	○	
28		Air gun		○	○	○	○	
29	Coolant gun		○	○	○	○		
30	Mist collector		○	○	○	○		
31	Precision machining option	Smart Thermal Compensation		●	●	●	●	
32		Linear scale	X / Y / Z axis		○	○	○	○
33		AICC I (40 block)		○	○	○	○	
34		AICC II (200 block)			○	○	○	
35	Automatic tool measurement	TS27R		○	○	○	○	
36		OTS		○	○	○	○	
37	Measurement & Automation	Automatic tool breakage detection		○	○	○	○	
38		Automatic workpiece measurement	OMP60		○	○	○	○
39		Automatic front door with safety device		○	○	○	○	
40	Others	LED Work light		●	●	●	●	
41		3 color signal tower		●	●	●	●	
42		4th axis auxiliary device interface		○	○	○	○	
43		Tool load monitoring		●	●	●	●	
44		EZ Guide i		○	○	○	○	
45	Automatic power off			○	○	○		

* Please contact Doosan to select detail specifications.

Peripheral equipments

Oil Cooler

An oil cooler correlated to room temperature can be equipped for a long-term operation at high speed. Cooling oil circulates around the spindle bearings to prevent thermal error of the spindle and maintain machining accuracy.



Chip conveyor option 23-25



Long



Short



Needle

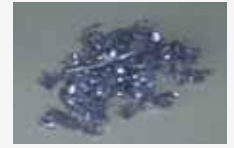

Sludge

Material		Carbon steel			Cast iron		Aluminium		
		Long	Short	Needle	Short	Sludge	Long	Short	Needle
Chip conveyor type									
Hinged belt type		○	△	X	△	X	○	△	X
Scrapper type	Normal	X	○	△	○	△	X	△	X
	Magnetic	X	○	○	○	○	—	—	—
Drum filter type	Hinged type	○	△	X	△	X	○	△	X
	Scrapper	X	○	△	○	△	X	○	△

○ : Suitable, △ : Possible, X : Not suitable

Measurement & Automation option 35-38



Automatic tool measurement



Automatic workpiece measurement

Raised block option 10-12

When the distance between the table top and the spindle nose needs to be extended, for example, accommodate a fixture or rotary axis on the table, raised block can be used to extend the distance.

Height **150mm (5.9 inch)**
200mm (7.9 inch)
300mm (11.8 inch)

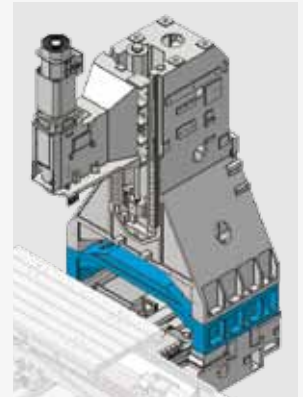

4th axis auxiliary device interface option 42

Users who wish to set up a rotary axis on the table to increase application flexibility are encouraged to contact Doosan in advance.

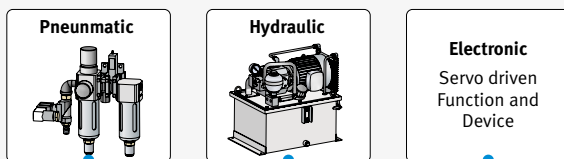

Hydraulic / Pneumatic fixture line option

The user should prepare pipelines for hydraulic/pneumatic fixtures whose detailed specifications should be determined by discussion with Doosan.

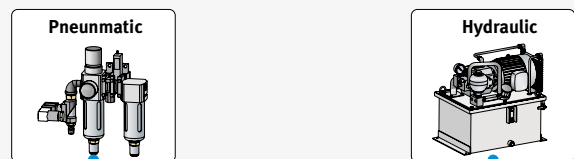



Basic Information

Basic Structure
Cutting
Performance

Detailed Information

Options
Applications
Diagrams
Specifications

Customer Support Service

User convenience has been significantly enhanced with a new operation panel.

Simple and Convenient Operation Panel

The operation panel is redesigned and integrated for better usability. Additionally, customized function switches can be attached to maximize operation convenience.



10.4" Display



- 10.4" Display
- USB & PCMCIA card (Std.)
- QWERTY type keyboard
- Easy to put button switch for attached option
- Ergonomic new design
- HOT KEY ①
To quick operate, some of buttons such as return reference point and tool management etc. are installed on the operation panel.
- Vertical Key②
Improving convenient to use NC functions.

Convenience Functions (Hot Keys)

Frequently used functions can be accessed and used quickly and easily by clicking the hot key buttons.



- ① Tapping retract function: A function readily releases tool by reverse rotating the spindle in manual mode when the tool is caught due to a power failure, emergency stop or NC reset.
- ② One-touch zero return function: Pressing in manual mode returns the z axis to the primary zero point.
- ③ ATC position return function: Pressing in manual mode returns the z axis to the secondary zero point, enabling tool magazine rotation.
- ④ Tool Load Monitoring function : Function to automatically monitor tool load

PCMCIA Card & USB Port

PCMCIA Card

The PCMCIA card enables uploading and downloading of the NC program, NC parameters, tool information, and ladder programs, and also supports DNC operation.

USB Port

The USB memory stick enables uploading and downloading of the NC program, NC parameters, tool information and ladder programs. (DNC operation is not supported.)

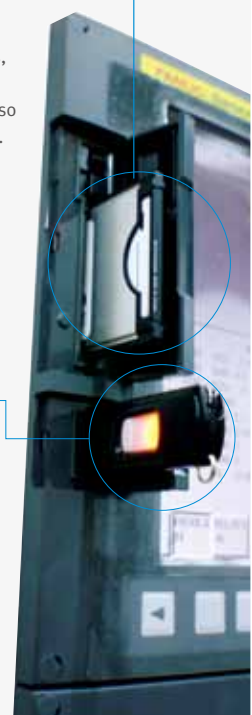

Easy Operation Package

The software developed by Doosan's own technology provides numerous functions designed for convenient operation.

Adaptive Feed Control (AFC)



Function to control feedrate so that the cutting can be carried out at a constant load (To adapt to the spindle load set up with constant load feedrate control function)

Tool Load Monitor



Function to automatically monitor tool load (Different loads can be set for one tool according to M700 ~ M704)

Work Offset Setting



Function to configure various work offset settings

Sensor Status Monitor



Function to view sensor conditions of the machine

Tool Management



Function to manage tool information [Tool information]
 - Tool No. / Tool name
 - Tool condition : normal, large diameter, worn/damaged, used for the first time, annual

Pattern Cycle & Engraving



Function to create frequently-used cutting programs automatically
 - Pattern Cycle: creates a program for a pre-defined shape
 - Engraving: creates a program for cutting a shape described with characters **option**

Alarm Guidance



Function to show detailed info on frequently triggered alarms and recommended actions

ATC Recovery



Function to view detailed info with recommended actions and to perform step-by-step operation manually (when an alarm is triggered during an ATC operation)

Spindle Power - Torque Diagram

Basic Information

Basic Structure
Cutting
Performance

Detailed Information

Options
Applications
Diagrams
Specifications

Customer Support Service

8000 r/min

DNM 500/50 II, DNM 650/50 II, DNM 750/50 II, DNM 750L/50 II

Max. spindle speed

8000 r/min

Max. spindle power

22 kW
(29.5 Hp)

Max. spindle torque

353.2 N·m
(260.7 ft-lbs)

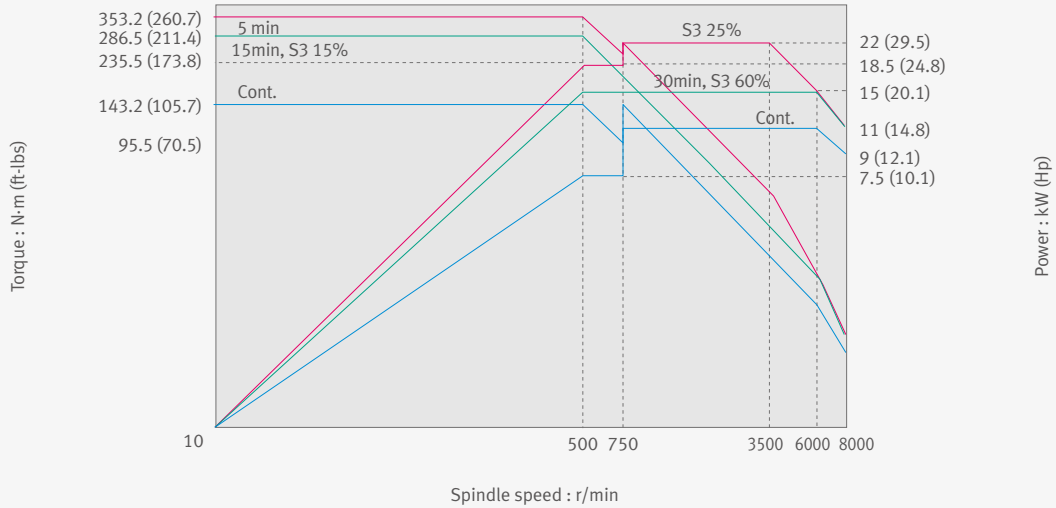

10000 r/min

DNM 500/50 II, DNM 650/50 II, DNM 750/50 II, DNM 750L/50 II

Max. spindle speed

10000 r/min

Max. spindle power

26 kW
(34.9 Hp)

Max. spindle torque

165.5 N·m
(122.1 ft-lbs)

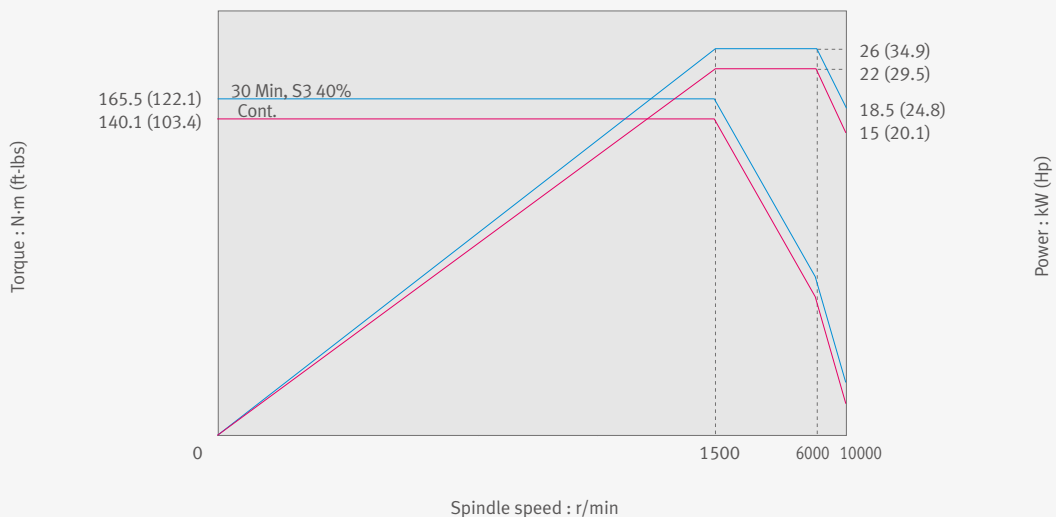

External Dimensions

DNM 500/50 II, DNM 650/50 II

Top View

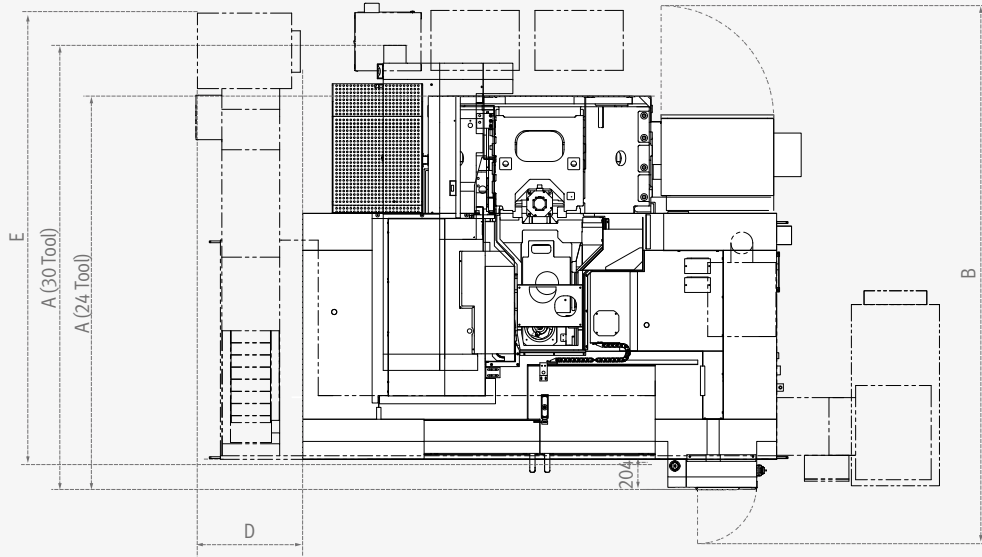

Front View

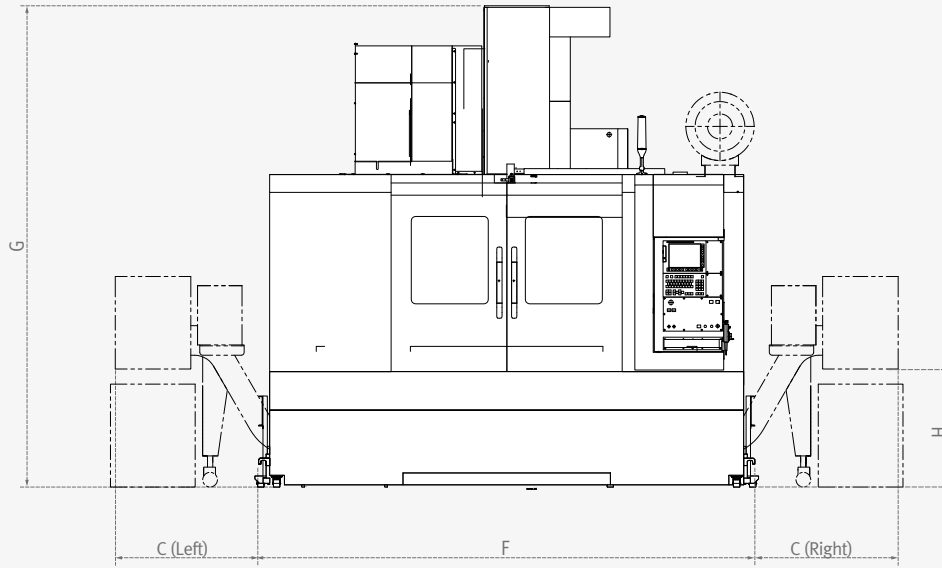

Unit: mm (inch)

Model	A (Length)	B (Max. machine length)	C (Additional width to accommodate the side chip conveyor)	D (Additional width to accommodate the rear chip conveyor)	E (Length to accommodate the rear chip conveyor)	F (Width)	G (Height)	H (Height from the floor to the chip outlet)
DNM 500/50 II	2412 (95.0)	3409 (134.2)	Left & Right : 951 (37.4)	710 (28.0)	3010 (118.5)	4061 (159.9)	3143 (123.7)	805 (31.7)
DNM 650/50 II	2656 (104.6) (24 Tool) 2999 (118.1) (30 Tool)	3633.5 (143.1)	Left & Right : 967.6 (38.1)	710 (28.0)	3010 (118.5)	3350 (131.9)	3250 (128.0)	805 (31.7)

External Dimensions

Basic Information

- Basic Structure
- Cutting
- Performance

DNM 750/50 II, DNM 750L/50 II

Detailed Information

- Options
- Applications
- Diagrams
- Specifications

Customer Support Service

Top View

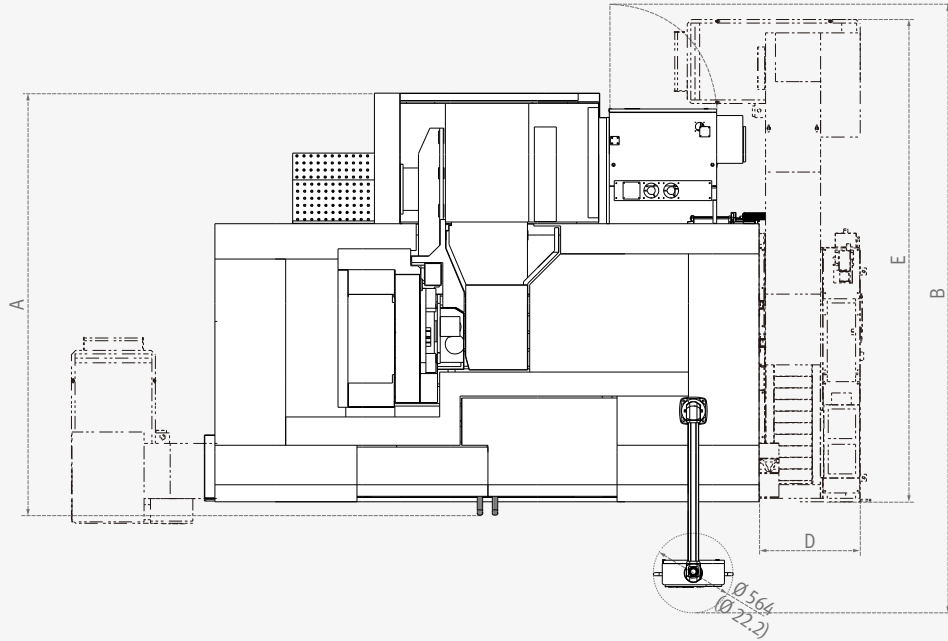

Front View

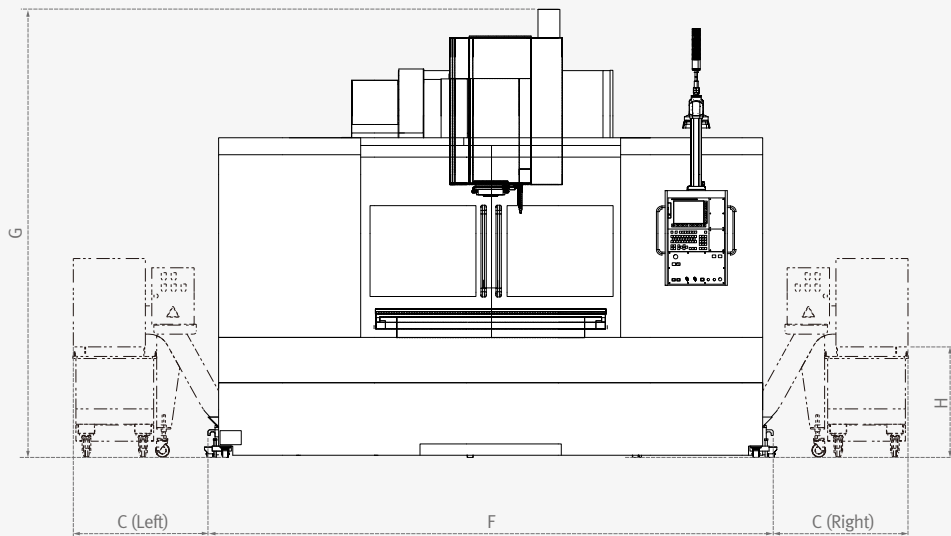

Unit: mm (inch)

Model	A (Length)	B (Max. machine length)	C (Additional width to accommodate the side chip conveyor)	D (Additional width to accommodate the rear chip conveyor)	E (Length to accommodate the rear chip conveyor)	F (Width)	G (Height)	H (Height from the floor to the chip outlet)
DNM 750/50 II	2986 (117.6)	4309 (169.6)	Left & Right : 953 (37.5)	790 (31.1)	3413 (134.4)	4000 (157.5)	3373 (132.8)	805 (31.7)
DNM 750L/50 II	2986 (117.6)	4309 (169.6)	Left & Right : 953 (37.5)	790 (31.1)	3413 (134.4)	5050 (198.8)	3373 (132.8)	805 (31.7)

Table

DNM 500/50 II

Unit: mm (inch)

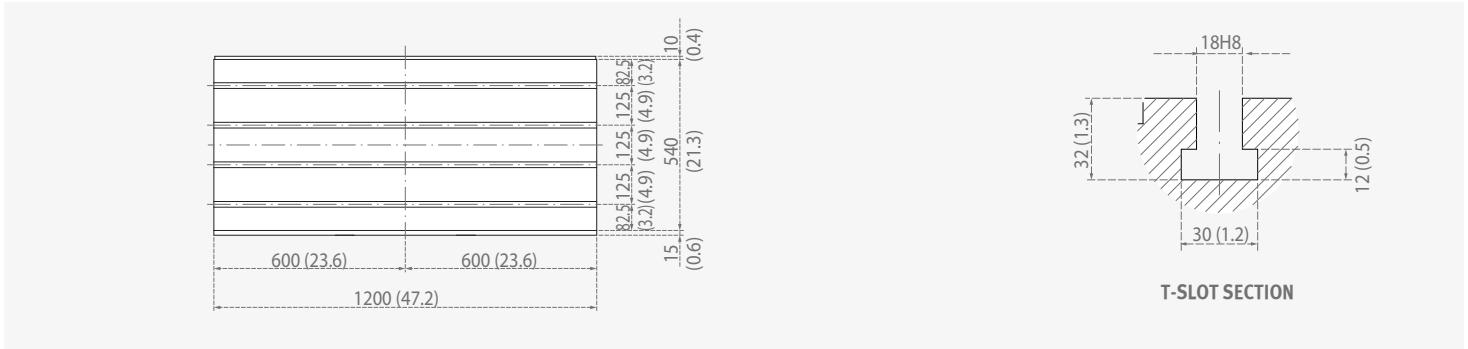

DNM 650/50 II

Unit: mm (inch)

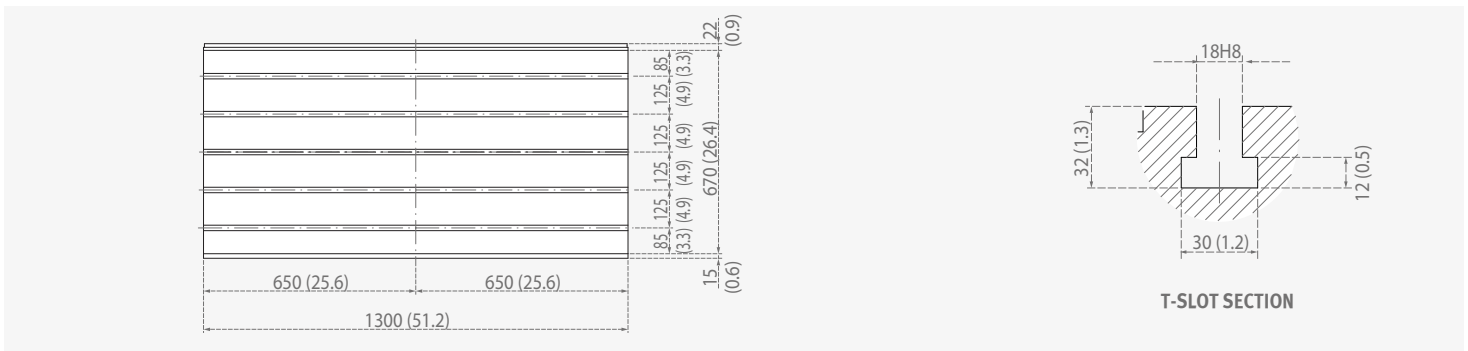

DNM 750/50 II

Unit: mm (inch)

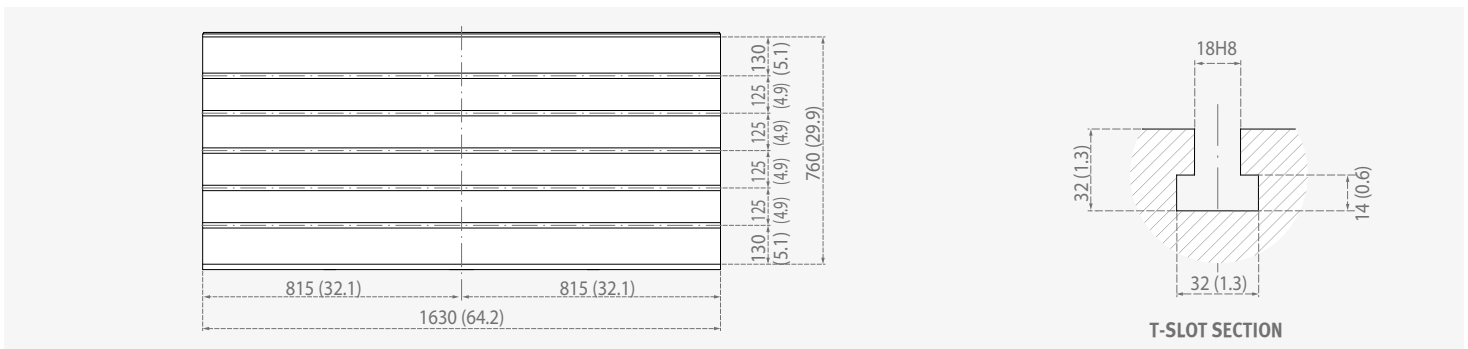

DNM 750L/50 II

Unit: mm (inch)

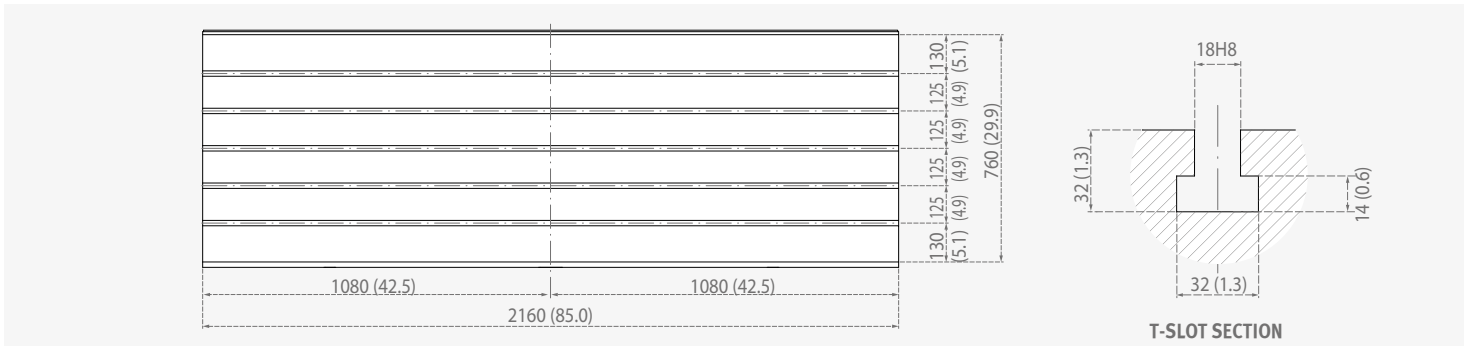

Basic Information

Basic Structure
Cutting
Performance

Detailed Information

Options
Applications
Diagrams
Specifications

Customer Support Service



Description		Unit	DNM 500/50 II	DNM 650/50 II	DNM 750/50 II	DNM 750L/50 II	
Travels	Travel distance	X axis	mm (inch)	1020 (40.2)	1270 (50.0)	1630 (64.2)	2160 (85.0)
		Y axis	mm (inch)	540 (21.3)	670 (26.4)	762 (30.0)	762 (30.0)
		Z axis	mm (inch)	510 (20.1)	625 (24.6)	650 (25.6)	650 (25.6)
	Distance from spindle nose to table top		mm (inch)	200 ~ 710 (7.9 ~ 28.0)	200 ~ 825 (7.9 ~ 32.5)	200 ~ 850 (7.9 ~ 33.5)	200 ~ 850 (7.9 ~ 33.5)
Table	Table size		mm (inch)	1200 x 540 (47.2 x 21.3)	1300 x 670 (51.2 x 26.4)	1630 x 760 (64.2 x 29.9)	2160 x 760 (85.0 x 29.9)
	Table loading capacity		kg (lb)	800 (1763.7)	1000 (2204.6)	1500 (3306.9)	1800 (3968.3)
	Table surface type		mm (inch)	T-SLOT [4-125(4.9) x 18 (0.7)H8]	T-SLOT [5-125 (4.9) x 18(0.7)H8]		
Spindle	Max. spindle speed		r/min	8000 {10000}*			
	Taper		-	ISO #50			
	Spindle power		kW (Hp)	22/11 (29.5/14.8) (S3 25%/Cont.) {26/22 (34.9/29.5) (S3 40%/Cont.)}*			
	Max. spindle torque		N·m (lbf·ft)	353.2 (260.5) (5min) {165.5 (122.0)(S3 40%)*}			
Feedrates	Rapid traverse rate	X axis	m/min (ipm)	36 (1417.3)		30 (1181.1)	24 (944.9)
		Y axis	m/min (ipm)	36 (1417.3)		30 (1181.1)	24 (944.9)
		Z axis	m/min (ipm)	30 (1181.1)		24 (944.9)	24 (944.9)
Automatic Tool Changer	Type of tool shank	Tool shank	-	BT 50 {CAT50/DIN50}*			
		Pull stud	-	MAS403 P50T-1 (45°)			
	Tool storage capa.		ea	24	24 {30}*		
	Max. tool diameter	Continuous	mm (inch)	125 (4.9)			
		Without Adjacent Tools	mm (inch)	220 (8.7)			
	Max. tool length		mm (inch)	350 (13.8)			
	Max. tool weight		kg (lb)	15 (33.1)			
	Max. tool moment		N·m (lbf·ft)	12.74 (9.4)			
	Tool selection		-	MEMORY RANDOM			
	Tool change time (Tool-to-tool)		sec	2.5			
Tool change time (Chip-to-chip)		sec	5.5				
Power source	Electric power supply (Rated capacity)		kVA	37.5 {51.5}*		40 {50}*	
	Compressed air supply		Mpa (psi)	0.54 (78.3)			
Tank capacity	Coolant tank capacity		L (gal)	300 (79.3)	380 (100.4)	480 (126.8)	525 (138.7)
Machine Dimensions	Height		mm (inch)	3143 (123.7)	3250 (128.0)	3385 (133.3)	3385 (133.3)
	Length		mm (inch)	2412 (95.0)	3350 (131.9)	3435 (135.2)	3435 (135.2)
	Width		mm (inch)	3110 (122.4)	2740 / 3000 (107.9 / 118.1)	3850 (151.6)	4900 (192.9)
	Weight		kg (lb)	6500 (14330.0)	8500 (18739.3)	13800 (30423.8)	15300 (33730.7)
Control	CNC system		-	DOOSAN FANUC i			

CNC Specifications

● Standard ○ Optional ✕ Not applicable

DOOSAN FANUC i

No.	Division	Item	Spec.	DOOSAN FANUC i
1	Axes control	Controlled axes	3 (X, Y, Z)	X, Y, Z
2		Least command increment	0.001 mm / 0.0001"	●
3		Least input increment	0.001 mm / 0.0001"	●
4	Interpolation & Feed function	2nd reference point return	G30	●
5		3rd / 4th reference return		●
6		Inverse time feed		●
7		Cylindrical interpolation	G07.1	●
8		Automatic corner override	G62	●
9		Manual handle feed	1 unit	●
10		Manual handle feed	x1, x10, x100 (per pulse)	●
11		Handle interruption		●
12		AI APC	20 BLOCK	●
13		AICC I	40 BLOCK	○
14	AICC II	200 BLOCK	○	
15	Spindle & M-code function	M- code function		●
16		Retraction for rigid tapping		●
17		Rigid tapping	G84, G74	●
18	Tool function	Number of tool offsets	400 ea	●
19		Tool nose radius compensation	G40, G41, G42	●
20		Tool length compensation	G43, G44, G49	●
21		Tool life management		●
22		Addition of tool pairs for tool life management		●
23		Tool offset	G45 - G48	●
24	Program- ming & Editing function	Custom macro		●
25		Macro executor		●
26		Extended part program editing		●
27		Part program storage	512KB (1280m)	●
28		Part program storage	2MB (5120m)	○
29		Inch/metric conversion	G20 / G21	●
30		Number of Registered programs	400 ea	●
31		Optional block skip	9 BLOCK	●
32		Optional stop	M01	●
33		Program number	04-digits	●
34	Playback function		●	
35	OTHER FUNCTIONS (Operation, setting & Display, etc)	Addition of workpiece coordinate system	G54.1 P1 - 48 (48 pairs)	●
36		Embedded Ethernet		●
37		Graphic display	Tool path drawing	●
38		Loadmeter display		●
39		Memory card interface		●
40		USB memory interface	Only Data Read & Write	●
41		Operation history display		●
42		DNC operation with memory card		●
43		Optional angle chamfering / corner R		●
44		Run hour and part number display		●
45		High speed skip function		●
46		Polar coordinate command	G15 / G16	●
47		Programmable mirror image	G50.1 / G51.1	●
48		Scaling	G50, G51	●
49		Single direction positioning	G60	●
50		Pattern data input		●

Responding to Customers Anytime, Anywhere

Basic Information

- Basic Structure
- Cutting
- Performance

Detailed Information

- Options
- Applications
- Diagrams
- Specifications

Customer Support Service

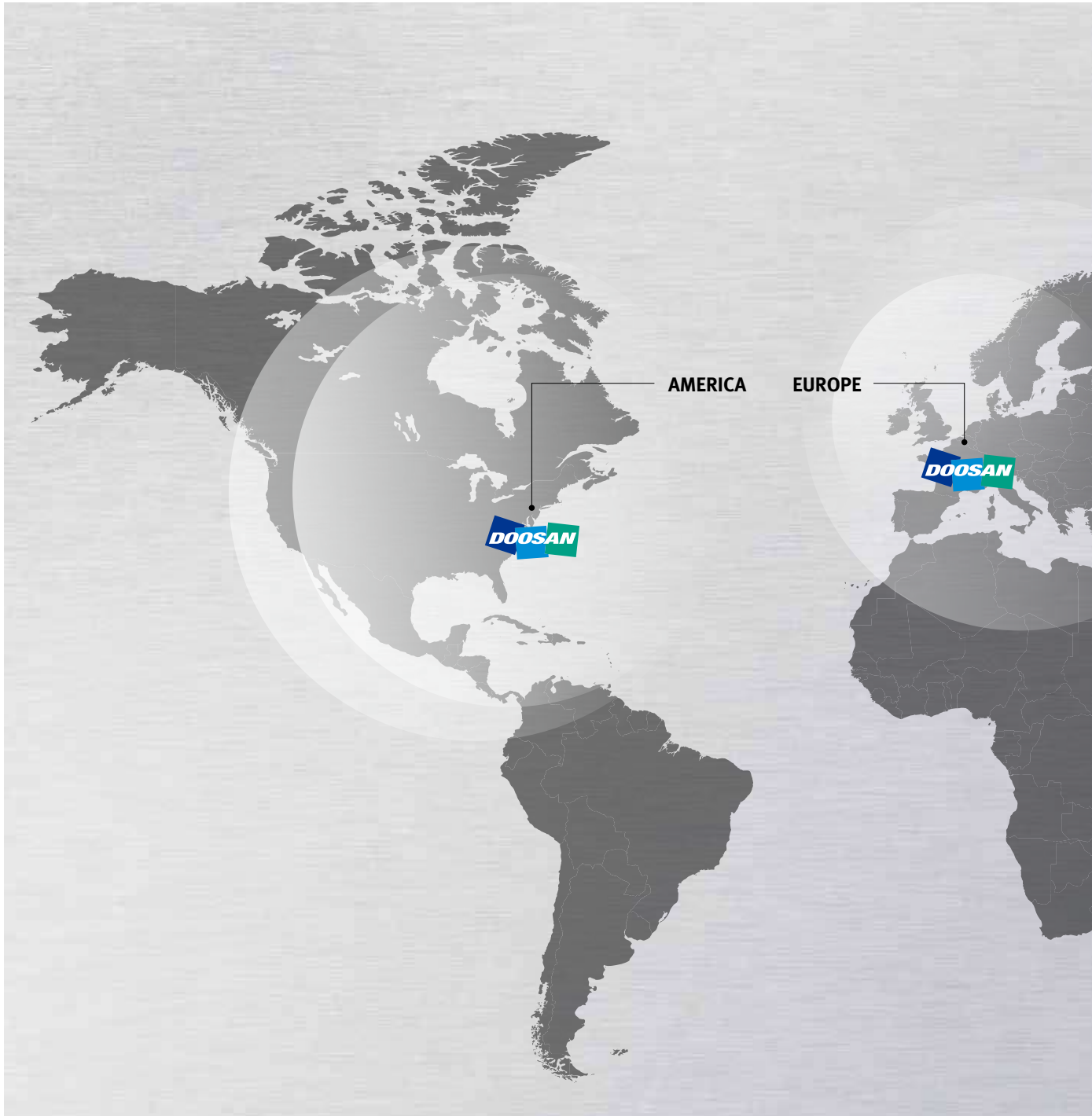

Global Service Support Network

Corporations

5

Dealer Networks

122

Technical Centers

18

Factories

3

Technical Center: Sales Support, Service Support, Parts Support

Doosan Machine Tools' Global Network, Responding to Customer's Needs nearby, Anytime, Anywhere

Doosan machine tools provides a system-based professional support service before and after the machine tool sale by responding quickly and efficiently to customers' demands.

By supplying spare parts, product training, field service and technical support, we can provide top class support to our customers around the world.



Domestic Service Support Network



Customer Support Service

We help customers to achieve success by providing a variety of professional services from pre-sales consultancy to post-sales support.

Supplying Parts



- Supplying a wide range of original Doosan spare parts
- Parts repair service

Field Services



- On site service
- Machine installation and testing
- Scheduled preventive maintenance
- Machine repair

Technical Support



- Supports machining methods and technology
- Responds to technical queries
- Provides technical consultancy

Training



- Programming / machine setup and operation
- Electrical and mechanical maintenance
- Applications engineering

Major Specifications

DNM #50 II series



Description	Unit	DNM 500/50 II	DNM 650/50 II	DNM 750/50 II	DNM 750L/50 II
Max. spindle speed	r/min	8000 {10000}*			
Max. spindle power	kW (Hp)	22 (29.5) {26 (34.9)}*			
Max. spindle torque	N·m (ft·lbs)	353.2 (260.7) {165.5 (122.1)}*			
Taper	-	ISO #50			
Travel distance (X / Y / Z)	mm (inch)	1020 / 540 / 510 (40.2 / 21.3 / 20.1)	1270 / 670 / 625 (50.0 / 26.4 / 24.6)	1630 / 762 / 650 (64.2 / 30.0 / 25.6)	2160 / 762 / 650 (85.0 / 30.0 / 25.6)
Tool storage capa.	ea	24	24 {30}*		
Table size	mm (inch)	1200 x 540 (47.2 x 21.3)	1300 x 670 (51.2 x 26.4)	1630 x 760 (64.2 x 29.9)	2160 x 760 (85.0 x 29.9)
CNC system	-	DOOSAN FANUC i			

*{ } Optional



Doosan Machine Tools

<http://www.doosanmachinetools.com>

www.facebook.com/doosanmachinetools

www.youtube.com/c/DoosanMachineToolsCorporation

**MACHINE
GREATNESS™**

Head Office

Yeonkang Bldg., 6th FL., 270, Yeonji-dong,
Jongno-gu, Seoul, Korea
Tel +82-2-3670-5345 / 5362
Fax +82-2-3670-5382

Doosan Machine Tools America

19A Chapin Rd., Pine Brook, NJ 07058, U.S.A.
Tel +1-973-618-2500
Fax +1-973-618-2501

Doosan Machine Tools China

Room 101,201,301, Building 39 Xinzhuan Highway
No.258 Songjiang District,China Shanghai(201612)
Tel +86-21-5445-1155
Fax +86-21-6405-1472

Doosan Machine Tools Europe

Emdener Strasse 24, D-41540 Dormagen, Germany
Tel +49-2133-5067-100
Fax +49-2133-5067-111

Doosan Machine Tools Japan

#2412, Mita Kokusai Bldg. 1-4-28 Mita,
Minato-ku, Tokyo 108-0073, Japan
Tel +81-3-5730-9013
Fax +81-3-5730-9016

Doosan Machine Tools India

106 / 10-11-12, Amruthahalli, Byatarayanapura,
Bellary road, Bangalore-560 092, India
Tel +91-80-4266-0122 / 121 / 100

* For more details, please contact Doosan Machine Tools.

* The specifications and information above-mentioned may be changed without prior notice.

* Doosan Machine Tools Co., Ltd. is a subsidiary of MBK Partners. The trademark  **DOOSAN** is used under a licensing agreement with Doosan Corporation, the registered trademark holder.